

Operative technique



ESTREMO Ankle Fusion Nail

Intramedullary nail for tibiotalo-calcaneal
arthrodesis

Citeffe thanks

Prof. Cesare Faldini, Director of 1st Orthopaedic and Traumatologic Clinic "IRCCS Istituto Ortopedico Rizzoli" Bologna, Italy, and his collaborators for their contribution in the product development and this operative technique.

Surgeons must always decide on the best approach to follow according to their clinical judgement and the patient's needs. Citeffe does not dispense medical advice and recommends that surgeons be trained in the use of any particular product before using it in surgery. The information presented is intended to demonstrate the extent of Citeffe product offerings.

Before use a surgeon must always consult the package insert, product label and/or instructions for use. Products may not be available in all markets because product availability is subject to the regulatory and/or medical practices in individual markets.

Please contact your Citeffe representative if you have questions about the availability of Citeffe products in your area.

PRODUCT DESCRIPTION.....	4
SURGICAL INDICATIONS AND ENTRY POINTS.....	8
OPERATIVE TECHNIQUE.....	10
DYNAMIC TALAR SCREW.....	20
PROXIMAL SCREWS.....	29
TIBIO-TALAR APPOSITION/COMPRESSION	35
LATERAL CALCANEAL SCREW.....	36
TALO-CALCANEAL APPOSITION/COMPRESSION (OPTIONAL)	41
POSTERIOR CALCANEAL SCREW	47
CENTERING GUIDE REMOVAL.....	52
INSERTION OF THE END CAP.....	53
ORDERING INFORMATION	54

PRODUCT DESCRIPTION

STERILE

Estremo Ankle Fusion Nail

- Right and left anatomical nail
- Made of ASTM F136 titanium alloy
- Available diameters: 10, 11, 12mm
- Available lengths: 150, 200, 250, 300mm
- Distal curvature: 4°
- Medial locking of the proximal screws
- Proximal screws rotated anteriorly 15°
- Multiple distal locking options
- Possibility of micrometric and independent tibio-talar and talo-calcaneal compression.
- Anti-pull-out system of the calcaneal screws
- Integrated and cannulated tibio-talar compression screw

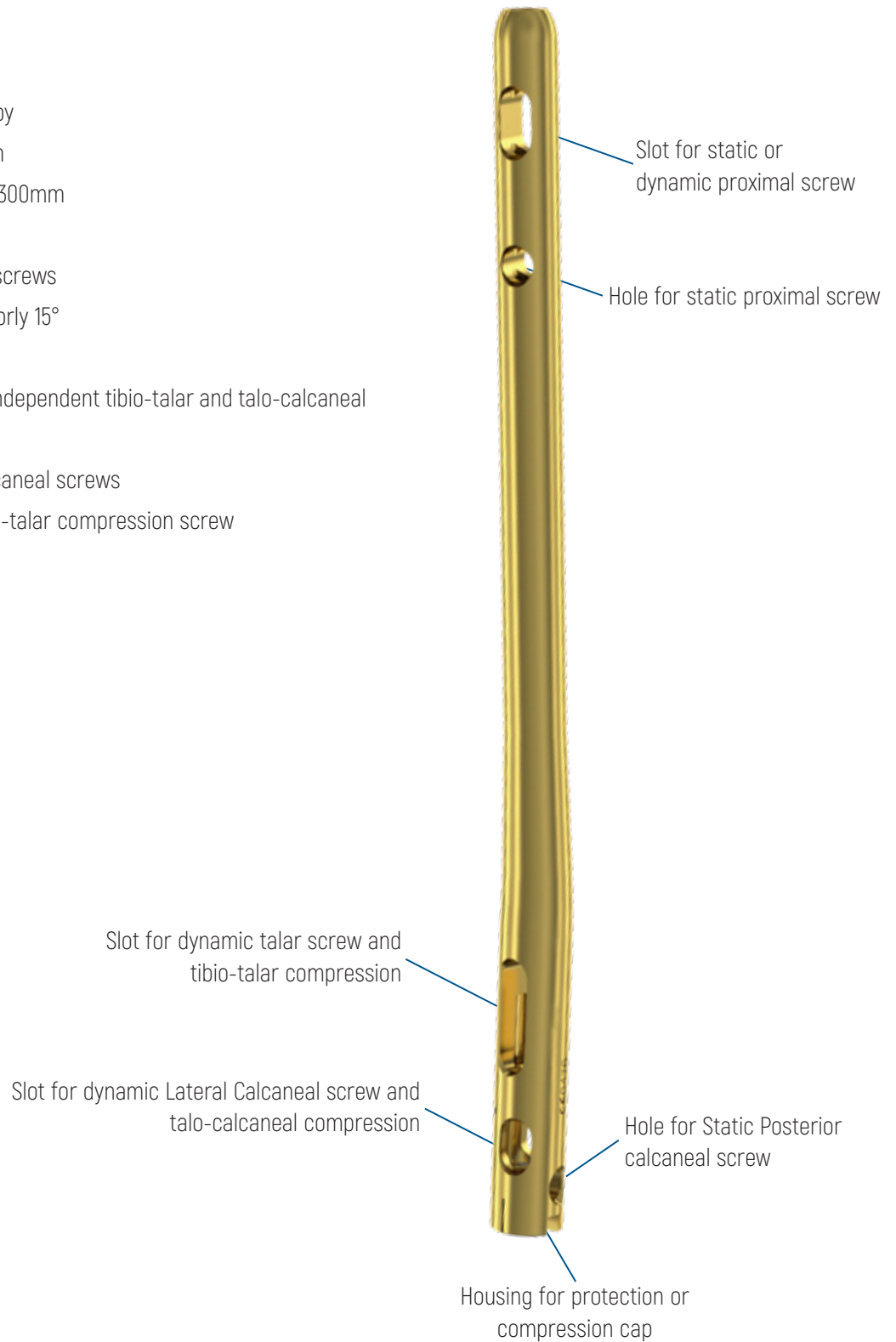

Estremo Ankle Fusion Nail design



The Estremo Ankle Fusion nail is designed to adapt to the anatomy of the tibi-talocalcaneal joint, allowing the restoration of correct axial alignment and ensuring stable and secure positioning of the screws even in the presence of significant bone loss.

The Estremo Ankle Fusion nail has a 4° distal valgus band, respecting the anatomy of the hindfoot alignment.

The proximal locking has a 15° mediolateral angle to avoid muscular and vascular-nervous damage.

The distal screws have different angles and different entry points to allow the correct positioning of the talar screw and the calcaneal screws.

In the distal portion it also has two slots for controlled tibio-talar and talo-calcaneal apposition/compression.

Anti pull-out system

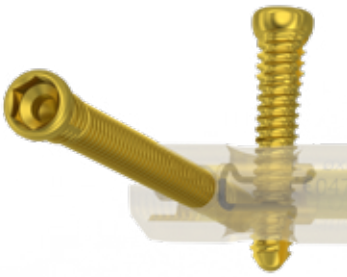

The hole of the calcaneal screws is characterized by an anti pull-out system that ensures screws stability and prevents their migration.

Tibio-talar compression

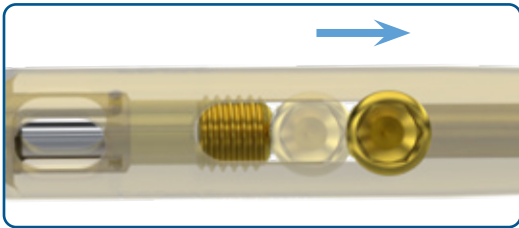

The Estremo Ankle Fusion nail features an integrated, cannulated tibio-talar compression screw. The integrated screw allows compression of up to 13mm.

Talo-calcaneal compression



Talo-calcaneal compression with compression cap

The Estremo Ankle Fusion nail features a cap for Talo-calcaneal compression. By acting on the lateral calcaneal screw, the cap allows compression of up to 3mm.



Talo-calcaneal compression cap

Talo-calcaneal compression with compression device

The Estremo Ankle Fusion nail features a device for Talo-calcaneal compression. By acting on the lateral calcaneal screw, the cap allows compression of up to 3mm.

NOTE:

The use of the posterior calcaneal screw is required to proceed to talo-calcaneal apposition/compression with compression device



Talo-calcaneal compression device

Compression Range

Tibio-talar Compression	13mm
Talo-calcaneal Compression	3mm

Estremo Ankle Fusion: protection/locking screws and caps

The head of the screws and of the caps of the Estremo Ankle Fusion Nail system is characterized by a retention system that allows them to remain integral with the screwdriver during insertion.

All Estremo Ankle Fusion screws and caps have a 5mm hex head allowing the use of just one screwdriver.

Cortical screw $\varnothing 5.2\text{mm}$

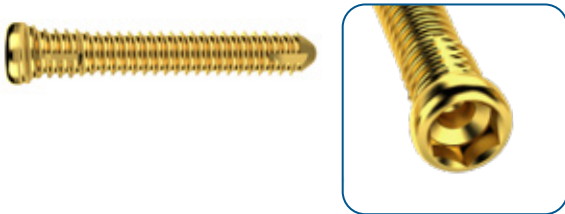

- Made of Titanium alloy
- Self-tapping
- Self retaining threaded head
- Available lengths: from 22.5mm to 110mm with 2.5mm increments (up to 55mm) and 5mm increments (up to 110mm)

End cap



Extra small

Medium

- Made of titanium alloy
- Self retaining threaded head
- Available lengths: extra small (0) and medium (+5mm)
- Prevents bone growth at the apex of the nail
- Increases the height of the nail in case of excessive sinking

Estremo Ankle Fusion: Talo-calcaneal compression cap

Controlled Talo-calcaneal apposition/compression up to 3mm can be applied at the talo-calcaneal joint by introducing a compression Screw from the end of the nail.

Talo-calcaneal compression cap



- Made of titanium alloy
- Performs Talo-calcaneal compression

NOTE:

It is not possible to use the posterior calcaneal screw when using the compression cap.

SURGICAL INDICATIONS AND ENTRY POINTS

Indications



The Estremo Ankle Fusion nail is indicated for tibiotalo-calcaneal arthrodesis.

Patient positioning

patient prone



The position of the patient is determined based on the type of arthrodesis to be treated and at the discretion of the surgeon.

The position options are:

- Patient prone
- Patient supine

patient supine

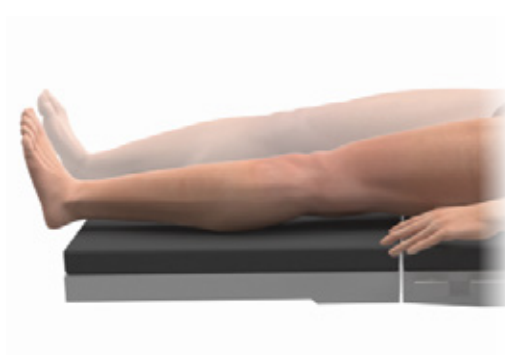

Position the patient in a supine position on the radiolucent table. Care should be taken to assure neutral alignment of the knee and ankle.

The use of a dedicated support to be placed under the leg to keep the limb raised by approximately 15 - 20 cm is recommended.

Positioning of the hindfoot for fusion

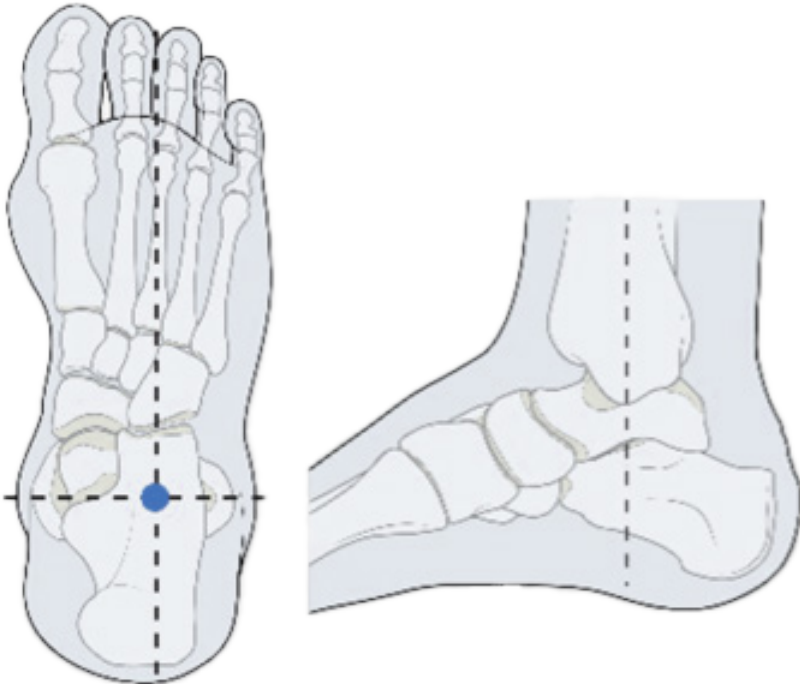

Position the foot with the ankle in neutral dorsal-plantar flexion, with external rotation of 5 - 10° in relation to the tibial crest; a 5° external rotation and eversion.

An assistant should hold this position for correct entry point determination.

Be sure to carefully prepare the articular surface and to verify the correct positioning under fluoroscopic guidance; the entry point is determined by the surgeon based on the clinical case to be treated.

INCISION AND ENTRY POINT¹

After joint preparation and confirmatory X-ray evaluation of the fusion position, the entry point can be determined by combining anatomical and fluoroscopic guidance.

First, a medial line is drawn along the tibial axis. Alternatively, this line can be visualized fluoroscopically by aligning a K. wire with the tibial canal on a lateral image.

From the plantar aspect, another line is drawn, starting at the center of the heel and extending toward the second ray.

The intersection of these two lines defines the entry point.

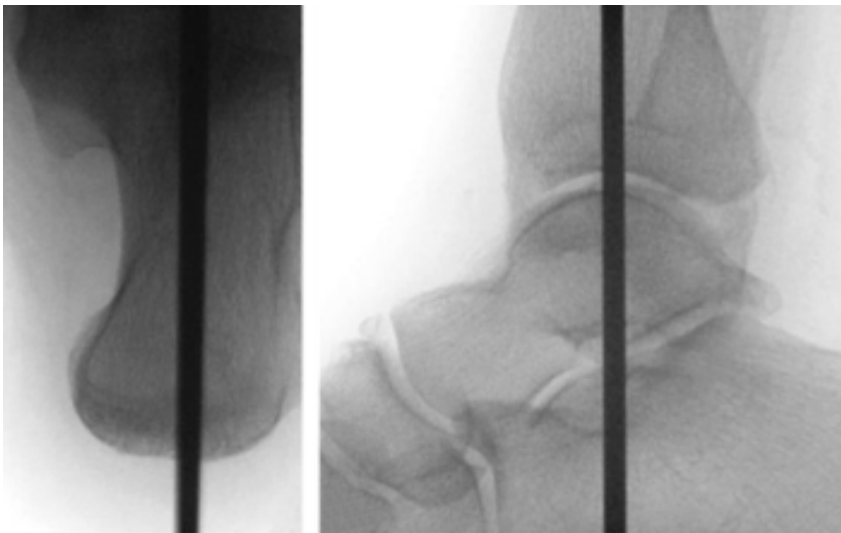

¹ Bibliography:

Zielli SO, Mazzotti A, Artioli E, Arceri A, Bonelli S, Ruffilli A, Faldini C. Retrograde intramedullary nail entry point for tibio-talo-calcaneal arthrodesis: a review of anatomical studies. *Eur J Orthop Surg Traumatol.* 2023;33(7):3185-3195.

OPERATIVE TECHNIQUE

The steps described illustrate the operative technique with the patient in the supine position and treatment of the left limb.

Entry point

Under fluoroscopic guidance, use the cannulated awl to prepare the entry point. Position the cannulated awl through the incision until it hits the bone to introduce the guide wire, trocar tip $\varnothing 3 \times 350 \text{mm}$.

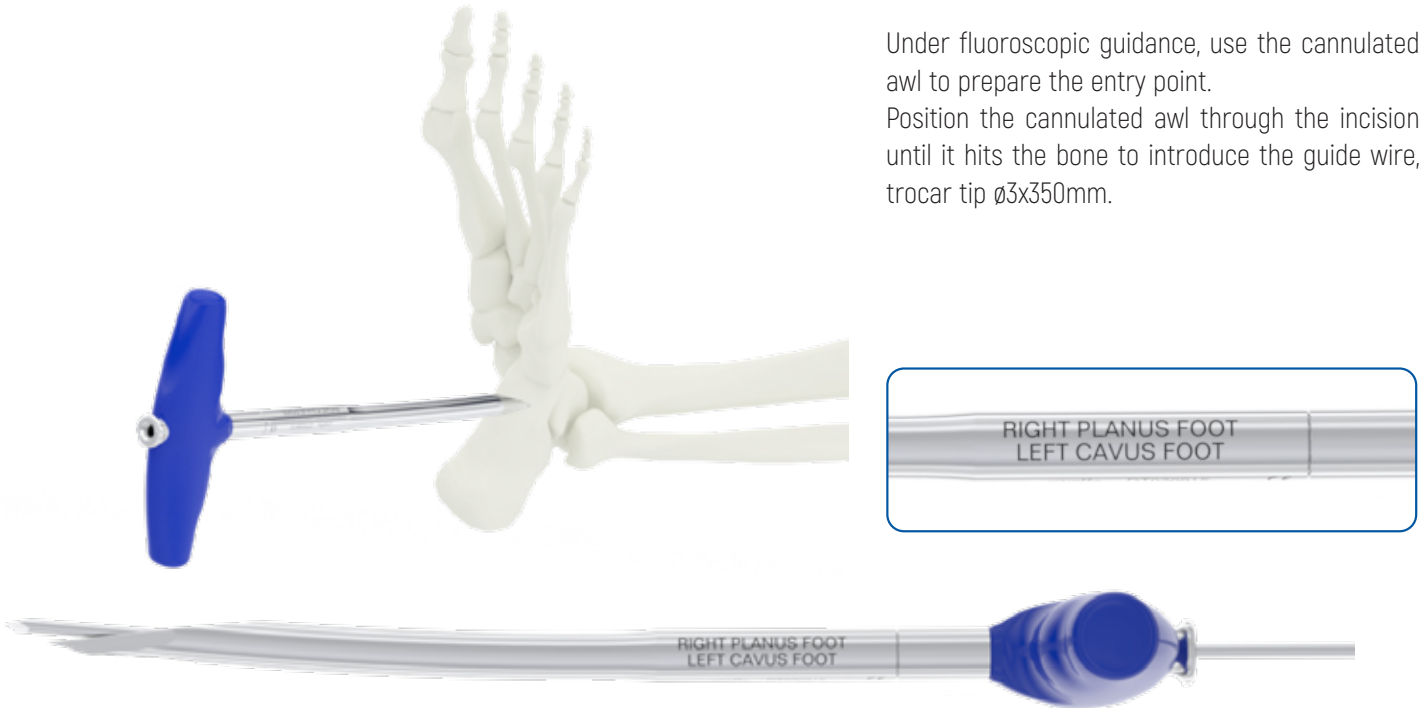

In case of planus foot or cavus foot to facilitate the introduction of guide wire it's possible to follow the marks on the cannulated awl:

Planus foot

In the planus foot, the guide wire will be located medial to the entry point of the cannulated awl.



Cavus foot

In the cavus foot, the guide wire will be located lateral to the entry point of cannulated awl.



INSTRUMENTS REQUIRED



DT030915

Manual cannulated awl $\varnothing 10 \text{mm}$

Insert the K. wire 3x350mm into the chuck and turn the ring nut anticlockwise to lock the guide wire in place.

Remove the chuck, by unscrewing the ring nut clockwise, and remove the cannulated awl.

Checking the position of the guide wire under fluoroscopic guidance

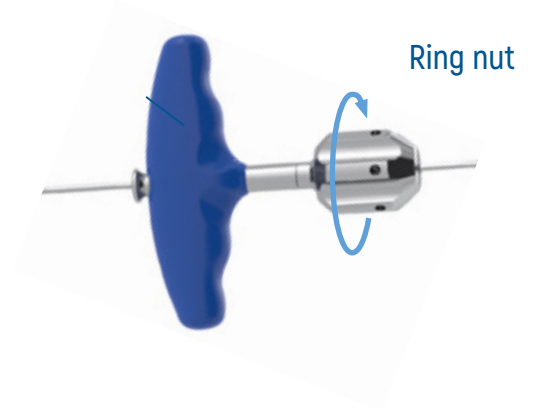

INSTRUMENTS REQUIRED



66987
Guide wire, trocar tip \varnothing 3x350mm, STERILE



EBA-5345
Chuck for \varnothing 2.5-3mm wire

Preparation of the intramedullary canal

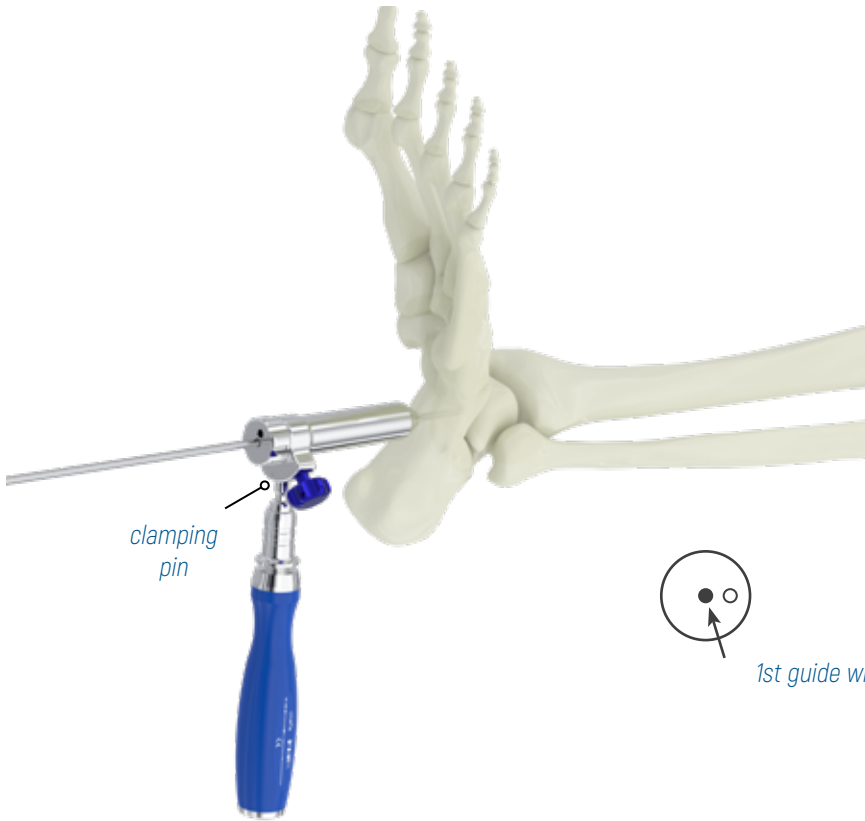

Position the Soft tissue protection sleeve with the Multi-hole Trocar inserted and screw the clamping pin.

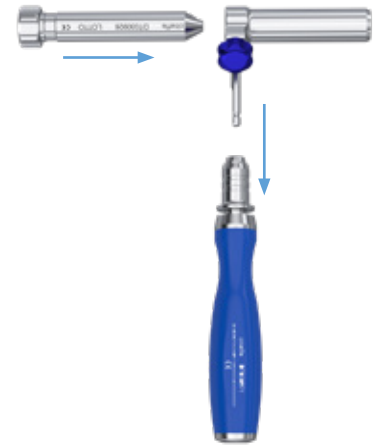

Insert through the incision, the Guide wire, into the central hole of the multi-hole trocar.

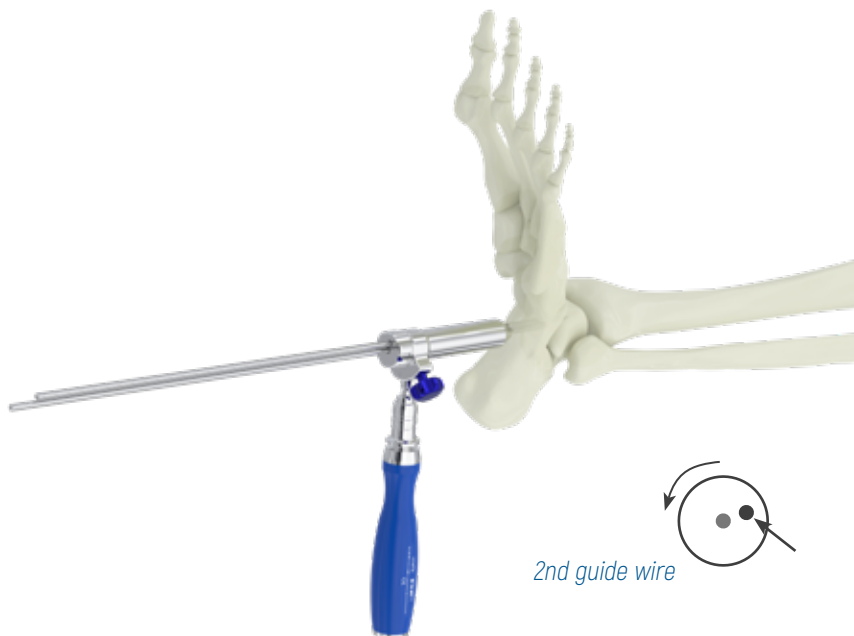

If the positioning of the Guide wire is not correct, unscrew the clamping pin and rotate the multi-hole trocar to position a second Guide wire, keeping the first wire in position.

Insert a second Guide wire to a depth of approximately 30mm and check its positioning.

If the second Guide wire is in line with the intramedullary canal, screw in the clamping pin and continue drilling.

After correctly positioning the second Guide wire, remove the first one, unscrew the clamping pin and remove the trocar.

INSTRUMENTS REQUIRED



66987

Guide wire, trocar tip $\varnothing 3 \times 350$ mm, STERILE



DT030971

Cannulated "D20" Handle with AO coupling



DT030922

Soft tissue protection sleeve AO joint



DT030926

Multi-hole trocar

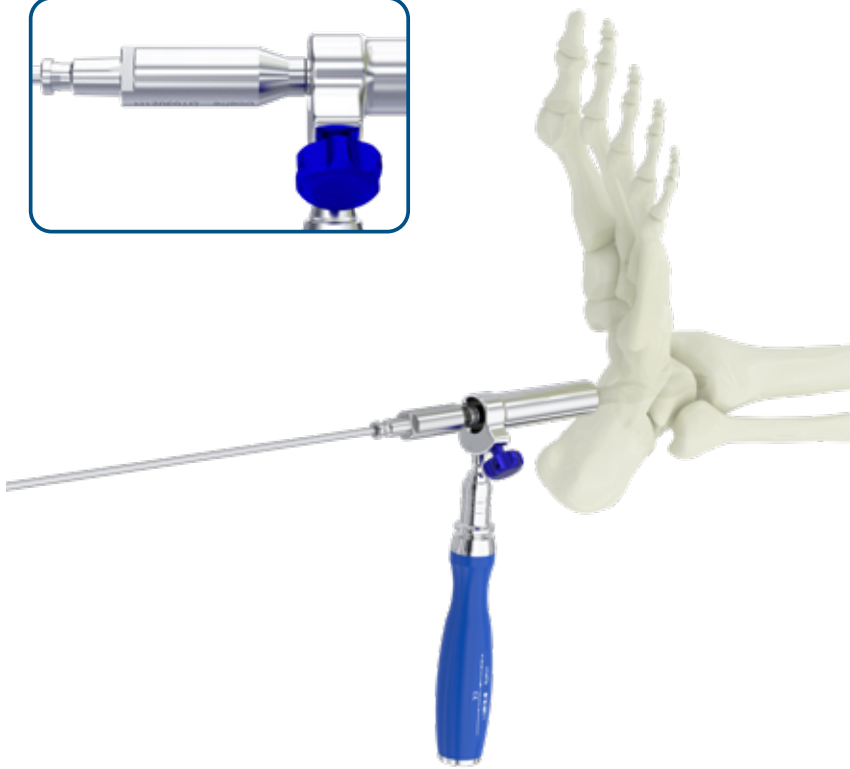

Pass the $\varnothing 11.5\text{mm}$ cannulated reamer through the soft tissue protection sleeve to drill through the corticals and subchondral bone of calcaneus and talus to the tibial plafond: avoiding contact with the posterior cortex.

Drill until the mark on the drill bit is reached.

Remove the cannulated reamer.

Remove the Guide wire.

NOTE:

If necessary repeat the reaming of the canal with the Cannulated reamer, $\varnothing 12.5\text{mm}$.

NOTE:

The distal portion is the same for all nails, regardless of diameter.

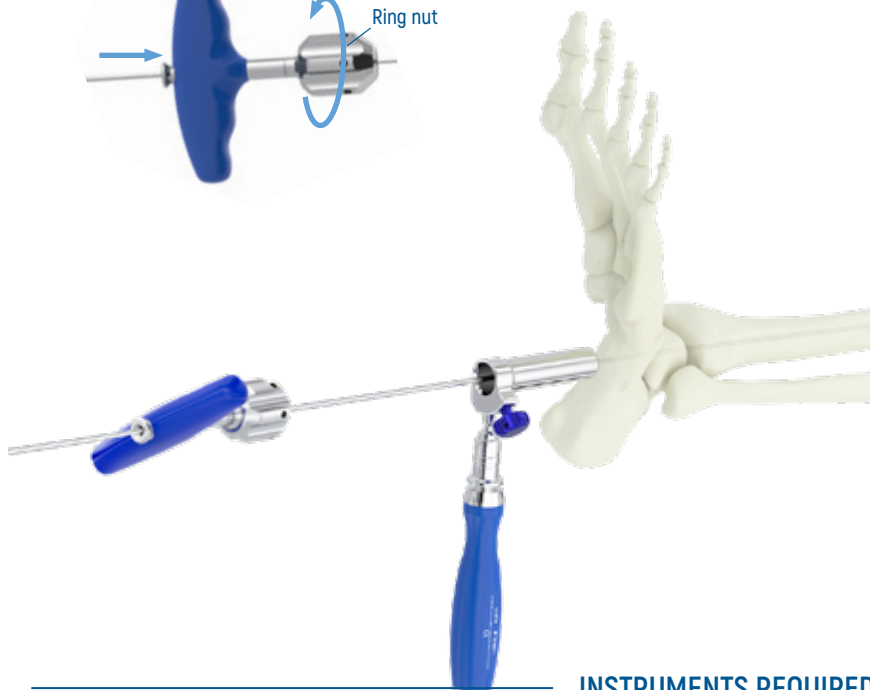
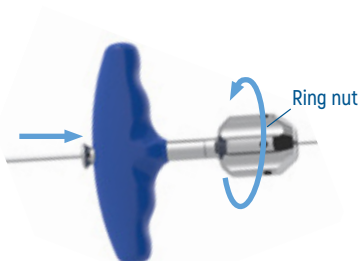

Insert the Guide wire with olive $\varnothing 2.5 \times 800\text{mm}$ into the Chuck for $\varnothing 2.5\text{mm}$ wire and turn the ring nut anticlockwise to lock the wire in place and insert it into the medullary canal to the desired depth.

Remove the chuck, by unscrewing the ring nut clockwise.

If necessary, ream the canal with progressive reamers (it is advisable to use a diameter at least 1.5mm larger than the nominal diameter of the nail to be implanted).

NOTE:

It is recommended to use the Obturator with handle in order to maintain the correct position of the guide wire.

Remove the soft tissue protection sleeve.

INSTRUMENTS REQUIRED



DT03021H
Cannulated reamer, $\varnothing 11.5\text{mm}$



EBA-5304
Guide wire with olive $\varnothing 2.5 \times 800\text{mm}$, STERILE



EBA-5345
Chuck for $\varnothing 2.5 - 3\text{mm}$ wire



DT030090
Obturator with handle

Nail length measurement and medullary canal reaming

Insert the Nails ruler onto the Guide wire with olive bringing it in contact with the cortex.



The images refers to the 150mm nail length

- 1) Make sure that the end of the Guide wire is in contact with the end of the nails ruler (the wire must be visible through the slot).
- 2) Read the length of the nail directly on the nails ruler marker.

! For intermediate readings, it is advisable to use the shorter nail.

Ream the canal progressively using 0.5mm increments. It is suggested to ream 1.5mm greater than the nail selected to implant.

NOTE:

In alternative can be used the Template nails length [DT030031, optional instrument] to identify nail diameter and length.

NOTE:

If necessary, it is possible to use the adapter GH5040 [Hudson-Hudson] or GH5041 [Zih-Zih].



INSTRUMENTS REQUIRED



DT030962
Nails ruler Kit with guide wire with olive $\varnothing 2.5 \times 800$ mm
STERILE

Nail-inserter assembly

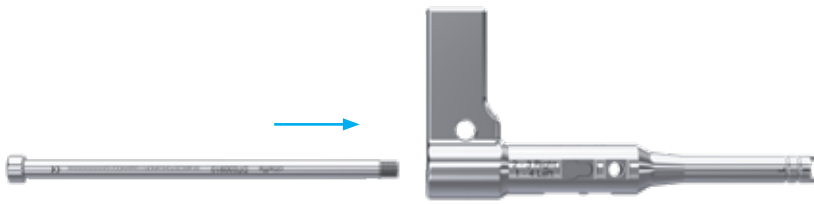

Insert the nail connection bolt into the dedicated hole of the nail inserter.

Example of assembly in case of left ankle

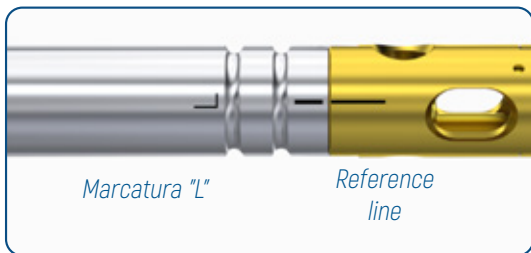

Attach the selected nail, length and diameter, to the nail inserter.

Proceed by engage until the two nail inserter connection teeth into the corresponding slots of the nail and matching the reference line on the nail with the "L" marker in the case of a left ankle or the "R" one in the case of a right ankle.

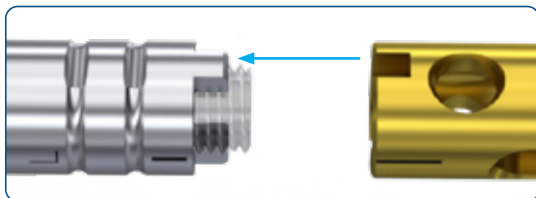

Connect the Cannulated T-handle on the wrench, 8mm and tighten the Nail Inserter connection screw.

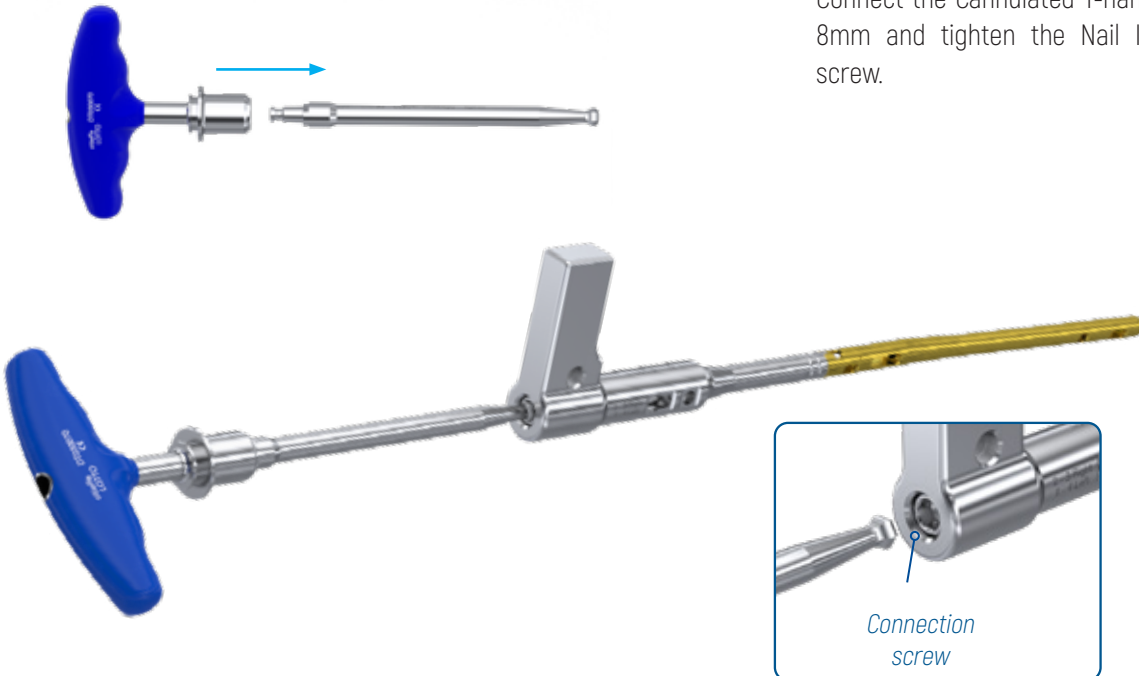

INSTRUMENTS REQUIRED



Insertion of the nail



Insert the nail over the Guide wire with olive $\varnothing 2.5 \times 800 \text{mm}$ to the desired depth.

Verify the correct position of the nail by checking the position, the depth and the rotation of the nail.

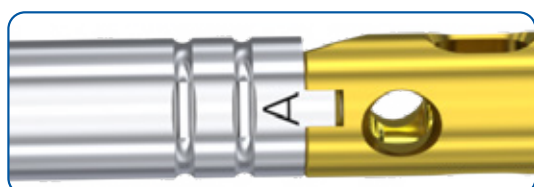

POSITIONING OF THE NAIL

The "A" marker located on the nail inserter, should correspond to the patient's anterior axis.

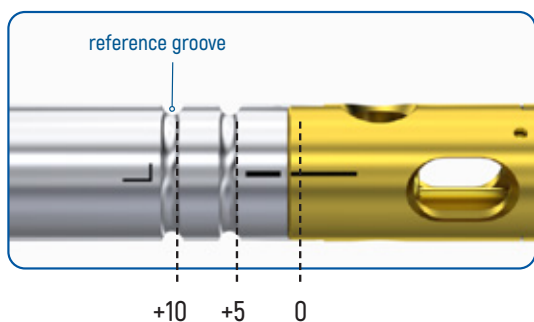

DEPTH CONTROL

Advance the nail into the intramedullary canal, if necessary, tap with the Slotted Hammer until reaching one of the two circumferential grooves located on the nail inserter post at 5mm and 10mm.

Under fluoroscopic guidance, the degree of sinking of the nail must be evaluated, taking into consideration the correct positioning of the talus hole and the amount of compression to be performed.

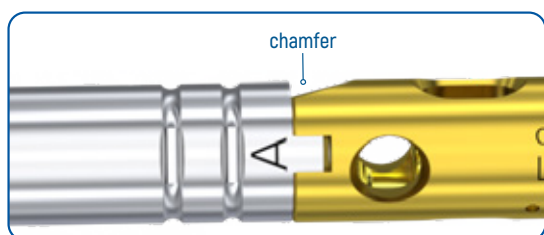

In the medial part of the end of the nail, a chamfer allows for the identification and correction of the depth and rotation.

Additionally, it's possible inserted a K. wire through the targeting device to identify the junction of the nail and nail inserter.

INSTRUMENTS REQUIRED



DT030080
Slotted hammer

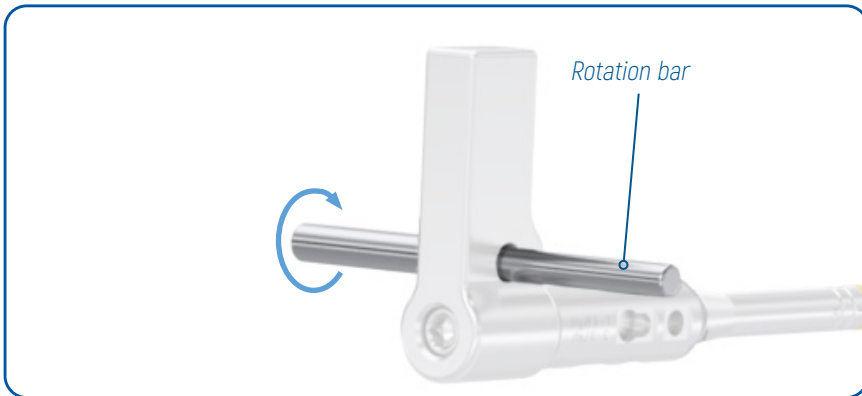

ROTATIONAL CONTROL

It is possible to check the correct rotation through the rotation bar to be inserted inside the hole on the Nail Inserter.

The correct position must be verified under fluoroscopic guidance.

Remove the Guide wire with olive $\varnothing 2.5 \times 800 \text{mm}$ and check the final position of the nail with lateral and anterior-posterior projections, checking the height of the holes corresponding to the segments to be stabilized.

The depth and rotation of the nail are determined by the correct positioning of the talar screw in the center of the talus body.

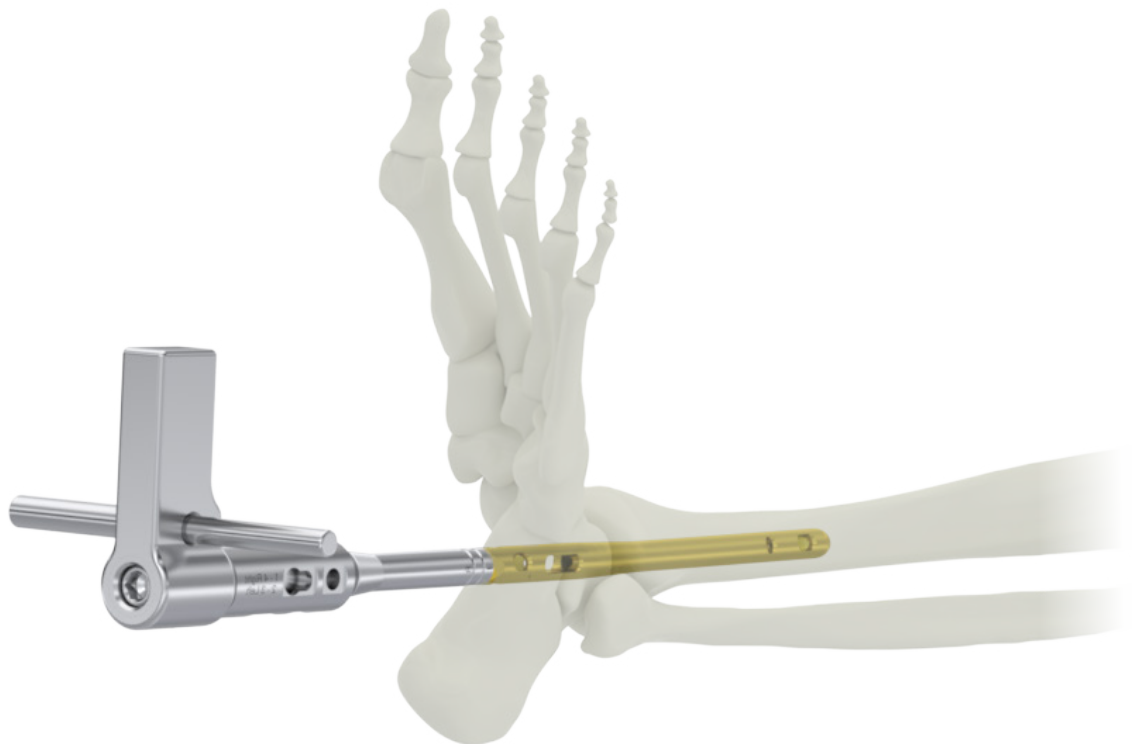

INSTRUMENTS REQUIRED



Nail Inserter
(ESTREMO ankle fusion guide DT030910)



Rotation bar
(ESTREMO ankle fusion guide DT030910)

Estremo ankle fusion targeting device

The Estremo Ankle Fusion targeting device consists of the Nail Inserter and the Estremo Ankle fusion Guide (hereinafter referred to as Centering Guide).

Different locking options can be achieved by connecting the Centering Guide to the different positioning holes on the Nail Inserter. The numbers indicated in correspondence with the holes ensure the correct alignment and pointing of the multi-planar screws in the nail.

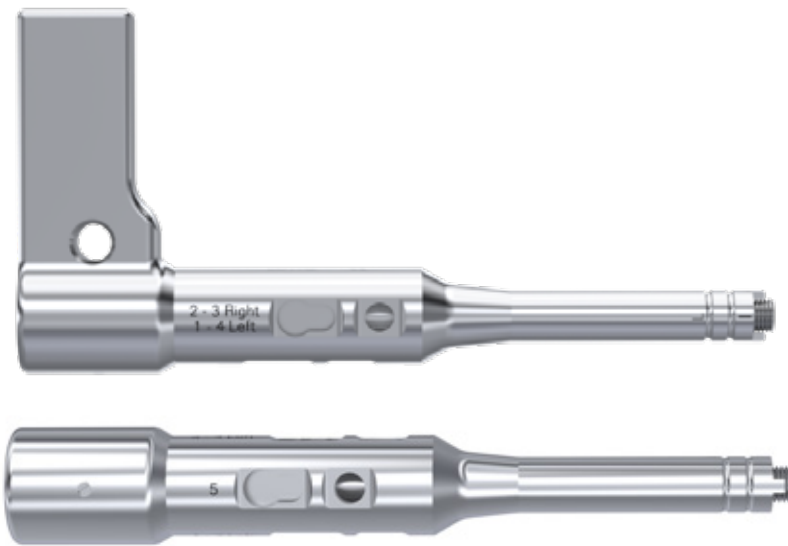

Nail Inserter

The numbers on the Centering Guide correspond to the screw site to be implanted.

Hole 1

Dynamic talar screw

Holes 3 and 2

Proximal screws with medial access.

Only for 150mm and 200mm nails.

Hole 4

Lateral calcaneal screw

Hole 5

Posterior calcaneal screw

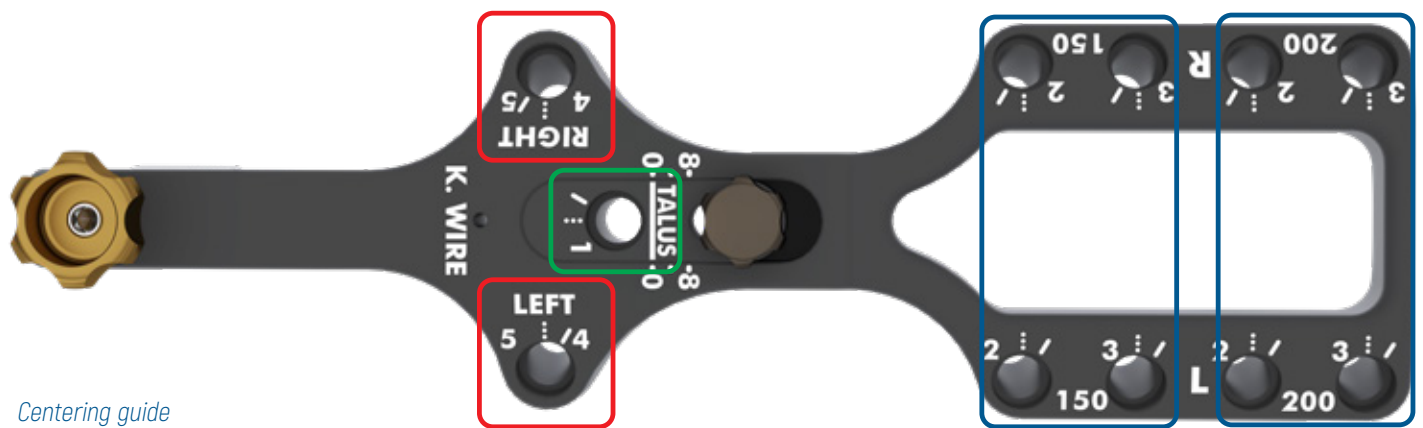

Centering guide

Estremo ankle fusion canula locking

The Estremo Ankle Fusion guide is equipped with a cannula retention system that keeps the cannula in place and prevents it from falling out. It also prevents the cannula from slipping during screw measurement.

To anchor the cannula, follow the steps below.

- 1 - Place the cannula in the guide and align the gold lever with the dotted line.
2. Turn the gold lever toward the continuous line.

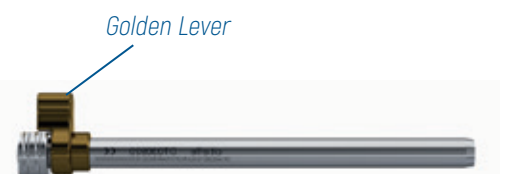

Locking options



The Estremo Ankle Fusion nail system features multiple locking options.

- Two proximal holes (one slot and one hole) rotated anteriorly by 15°
- A slot for placement of dynamic lateral talar screw
- A slot for placement of a dynamic lateral calcaneal screw
- A hole for placement of a posterior calcaneal screw

Hole 1

Dynamic talar screw

Holes 3 and 2

Proximal screws with medial access
Only for 150mm and 200mm nails

Hole 4

Lateral calcaneal screws

Hole 5

Posterior calcaneal screws

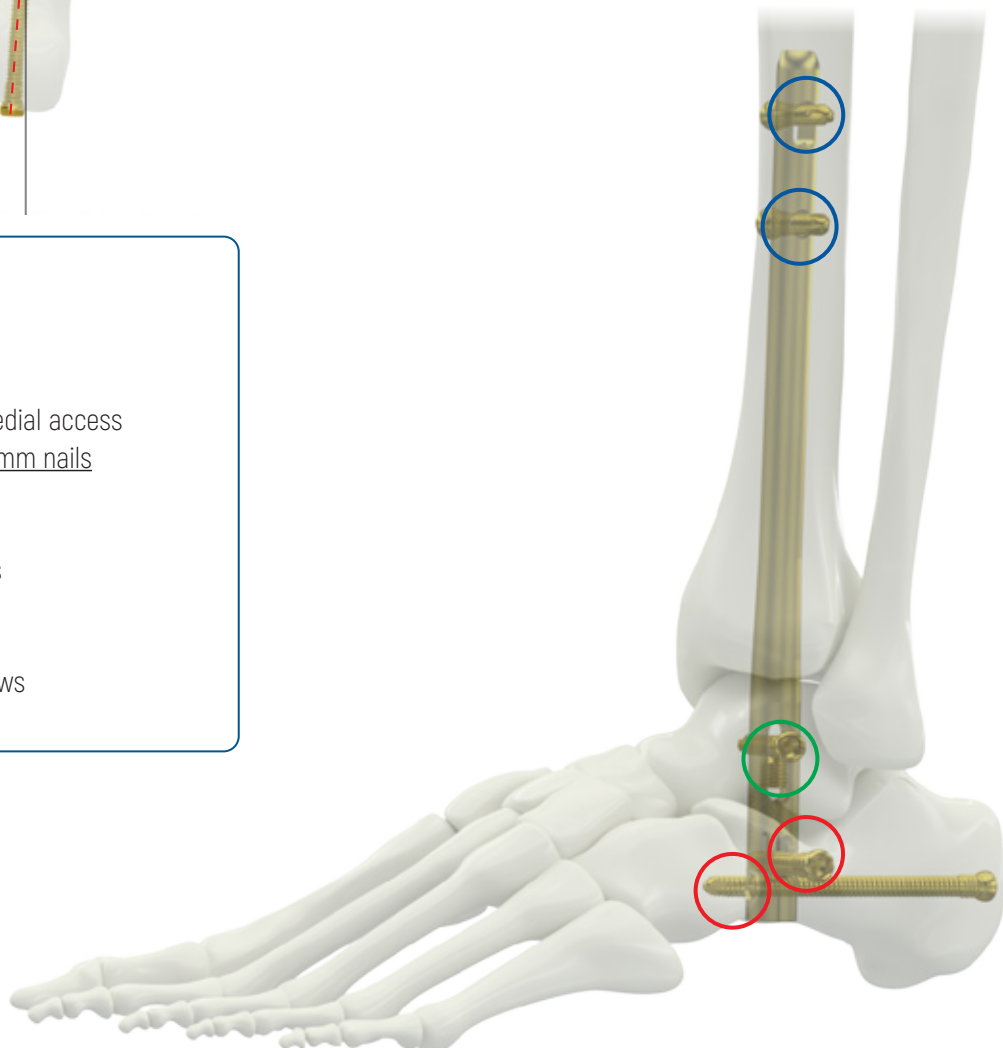

DYNAMIC TALAR SCREW



Hole 1

Dynamic talar screw



Nail Inserter

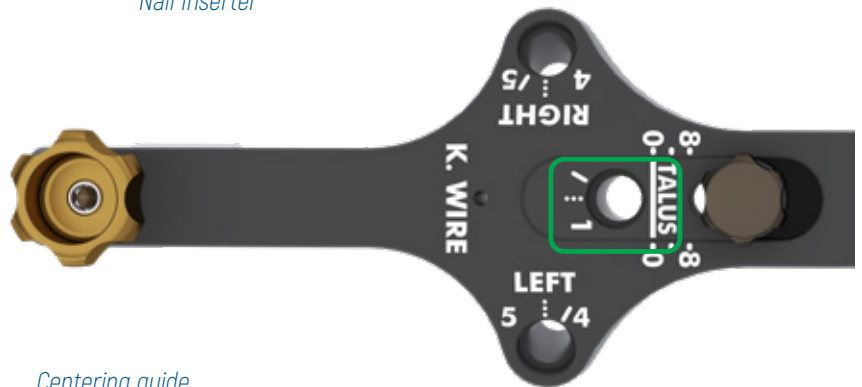

Centering guide

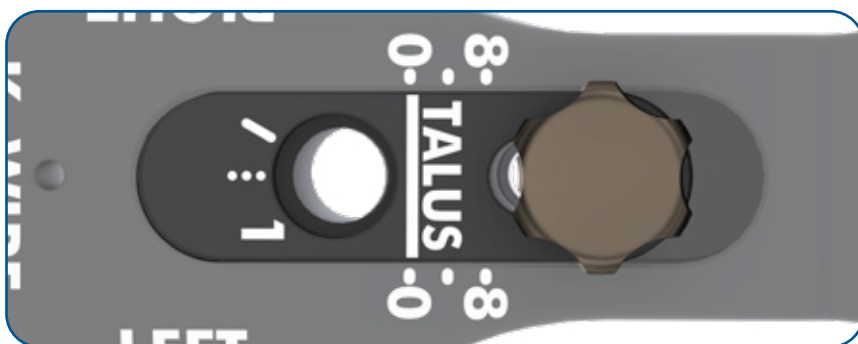

The centering guide allows the position of the screw to be adjusted in relation to the residual thickness of the talus. Through the slider, a proximal displacement of the screw in the slot of up to 8mm can be performed.

INSTRUMENTS REQUIRED



Nail Inserter
(ESTREMO ankle fusion guide DT030910)



DT030910
ESTREMO ankle fusion guide

The operative technique steps illustrated here refer to the left limb.

Centering guide assembly

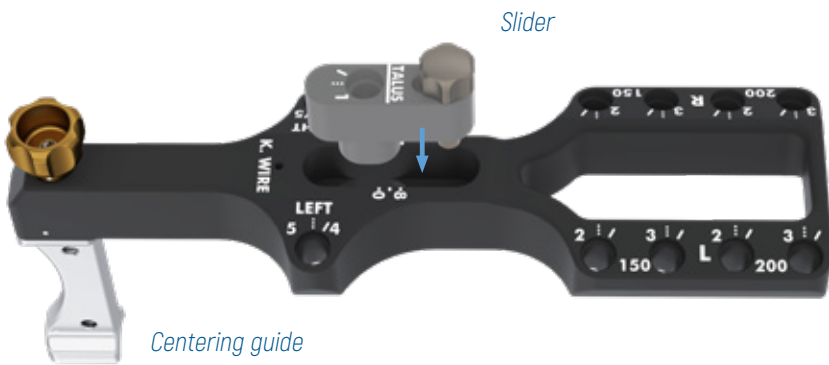

The centring guide has a slider in the centre section, which should be assembled as follows:

Insert the slider into the guide's housing, aligning the marker with the 0 on the guide.
Turn the gold knob clockwise to lock the slider in place.

To proceed with the insertion of the dynamic talar screw it is necessary to assemble the Centering Guide to the lateral position in correspondence with the marker "1-4 left".

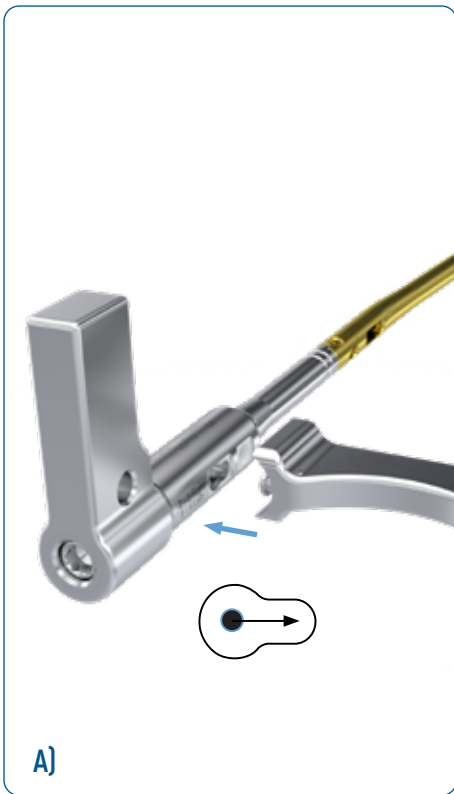

A: Insert the guide in correspondence with the marker "1 - 4 left" of the Nail Inserter.

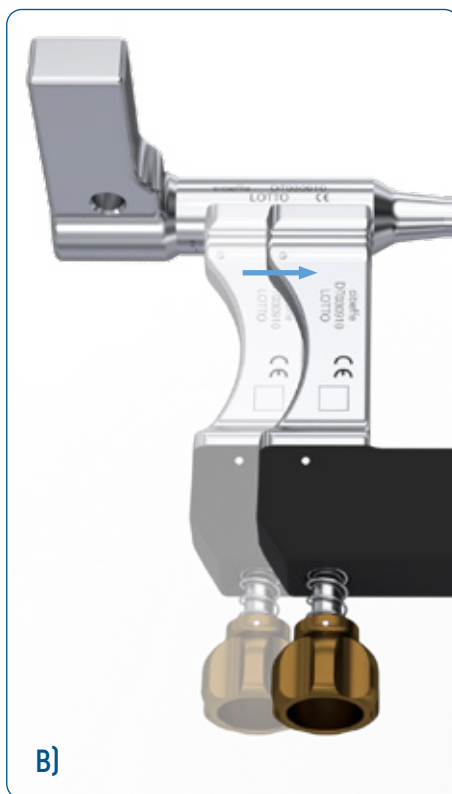

B: Move the guide proximally

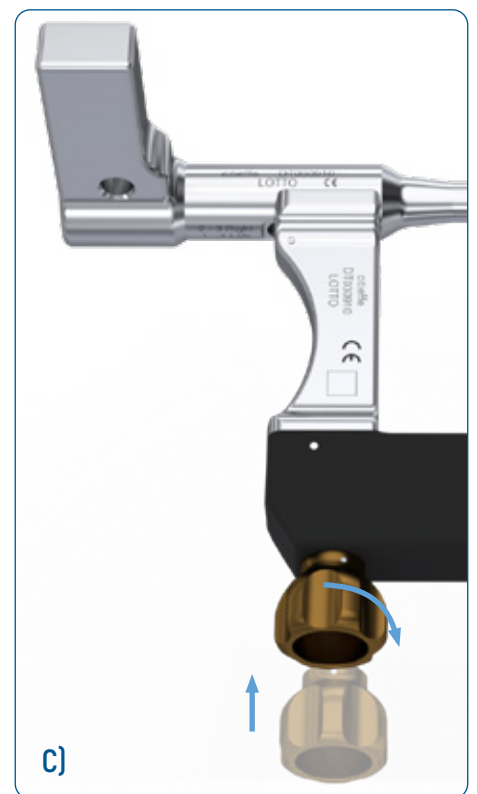

C: Press and screw the golden knob clockwise.

INSTRUMENTS REQUIRED



Nail Inserter
(ESTREMO ankle fusion guide DT030910)



DT030910
ESTREMO ankle fusion guide

Nail depth control

Insert a Guide wire, trocar tip $\varnothing 3 \times 350 \text{mm}$, through the hole in the centering guide marked **K. WIRE**. The tip of the wire indicates the distal end of the nail.

Check under fluoroscopy guidance the correct sinking of the nail (bearing in mind that in case of subsequent intraoperative compression the nail will move distally up to 13mm).

Remove the guide wire.

If present, remove the rotation bar.

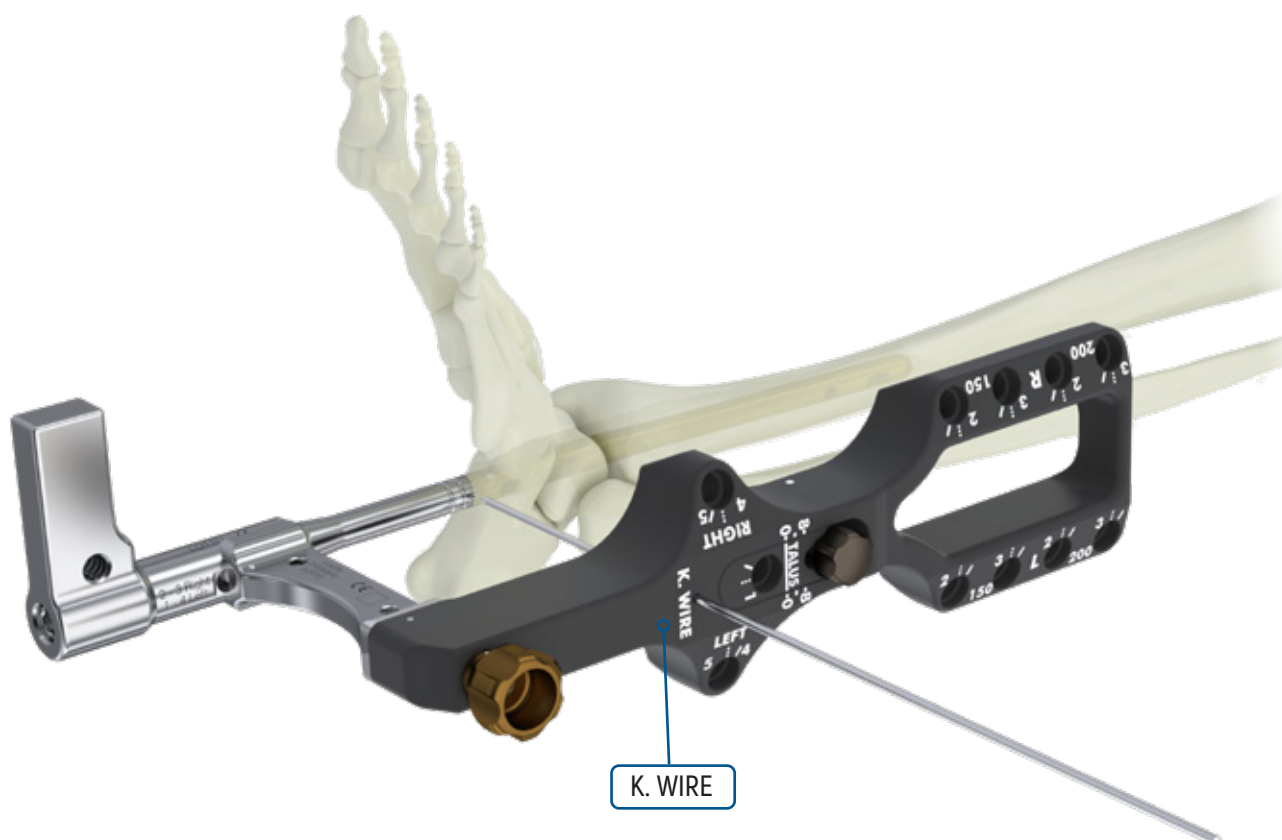

INSTRUMENTS REQUIRED

66987

Guide wire, trocar tip $\varnothing 3 \times 350 \text{mm}$, STERILE

Dynamic talar screw placement

The guide features a slider that allows the screw to be positioned in the center of the talus. The slider allows a range of motion from 0 to 8mm.

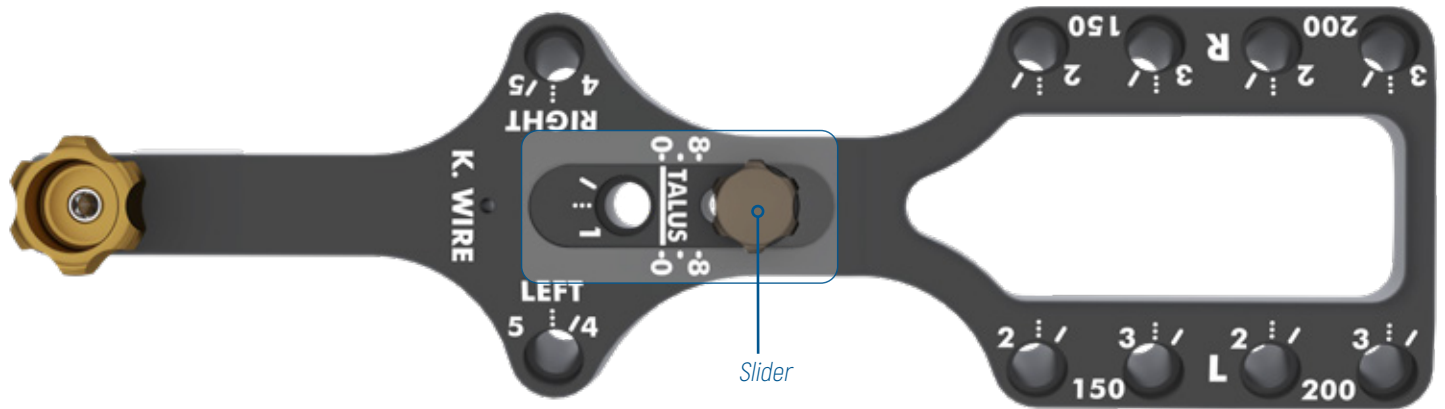

To perform the correction:

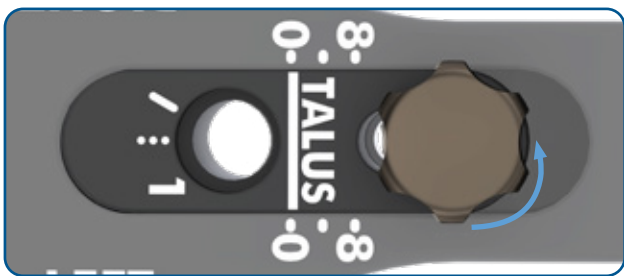

A) Unscrew the talus knob anticlockwise.

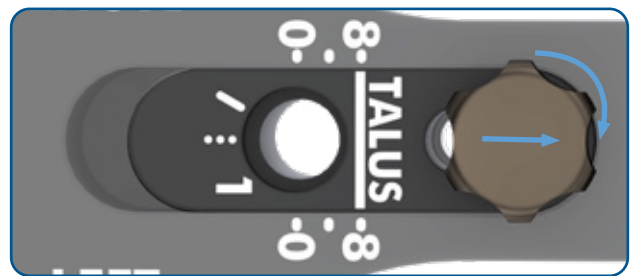

B) Translate the slider proximally to the desired position (up to 8mm) and screw the talus knob clockwise.

A radiolucent trocar (optional instrument) can be used for optimal visualization under fluoroscopy; alternatively, stainless steel trocar and cannula can be used directly.

If the slider is positioned totally proximally (8mm) it will still be possible to perform tibio-talar apposition/compression up to 5mm.

INSTRUMENTS REQUIRED



DT030910
Estremo ankle fusion guide

Dynamic talar screw placement with radiolucent trocar (optional)

Under fluoroscopy guidance, locate the position of the slider to insert the talar screw in correspondence with the hole marked ①.

Make sure the guide is in the lateral position.

NOTE:

Positioning this screw will allow, subsequent controlled apposition/compression up to a maximum of 13mm.

Correct screw position must be in the centre of the talus body.

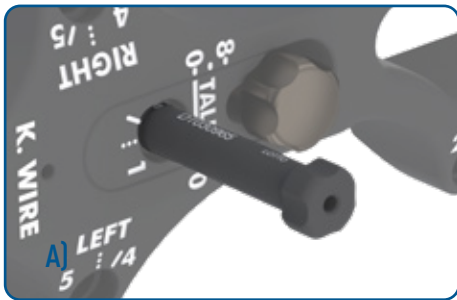
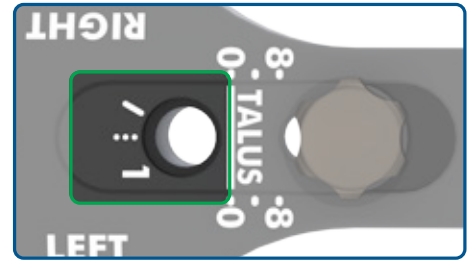

A- Locate the incision point by introducing the radiolucent trocar into the hole marked ①

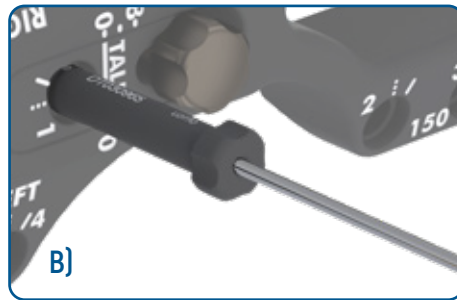

B- Insert the Guide wire, trocar tip $\varnothing 3 \times 350$ mm into the trocar.



C- Under fluoroscopy check the correct position of the tip of the Guide wire centre of the talus body.

If necessary, remove the guide wire and correct the position using the slider on the centering guide, following the step.

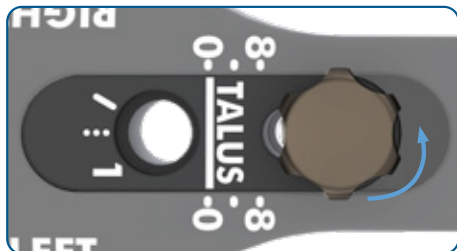
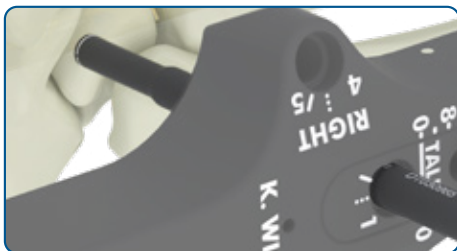

A) Unscrew the talus knob anticlockwise.

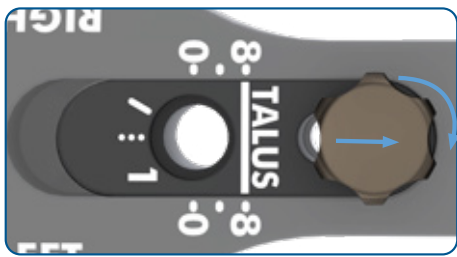

B) Translate the slider proximally to the desired position (up to 8mm) and screw the talus knob clockwise. Insert the guide wire into the trocar and check the correct position.

Allert: ensure that an incision has been made to ensure the correct movement of the trocar.

Once reach the desiderate position of the screw, replace the radiolucent trocar and remove the guide wire.

Proceed with the operative technique steps: Dynamic talar screw placement (pag 25).

If the slider is positioned totally proximally (8mm) it will still be possible to perform tibio-talar apposition/compression up to 5mm.

INSTRUMENTS REQUIRED



DT030965
Radiolucent trocar $\varnothing 3$ mm STERILE



66987
Guide wire, trocar tip $\varnothing 3 \times 350$ mm, STERILE

Dynamic talar screw placement

Under fluoroscopy, locate the position of the slider to insert the talar screw in correspondence with the hole marked ①. Make sure the guide is in the lateral position.

NOTE:

Positioning this screw will allow, subsequent controlled apposition/compression up to a maximum of 13mm.

Correct screw position must be in the center of the talus body.

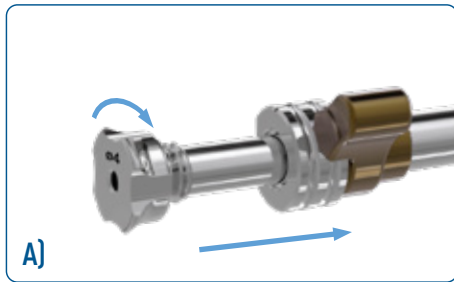
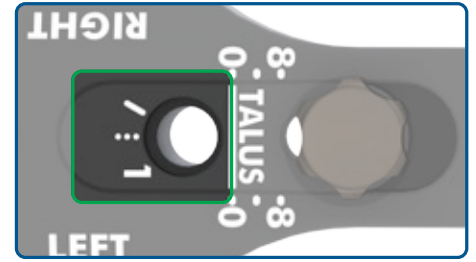

A- Insert the Trocar for drill bit into the Cannula, rotating it clockwise.

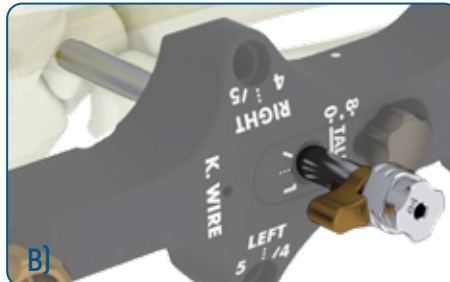

B- Locate the incision point by introducing the trocar with the cannula into the hole marked ① and bring it into contact with the skin. Make a small incision at the tip of the trocar and rotate the cannula and trocar through the soft tissue until they come into contact with the cortical bone.

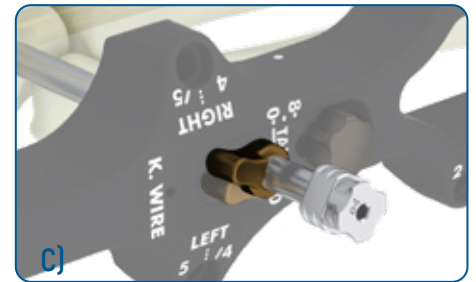

C- Bring the lever of the Cannula closer to the seat of the centering guide and rotate it to anchor the Cannula to the guide following the marker.

Under fluoroscopic guidance, check that the cannula is positioned in the centre of the talus body.

If the Radiolucent Trocar has not been used, if necessary, adjust the position using the slider on the centering guide, following the steps described below:

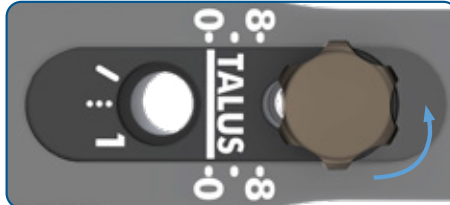
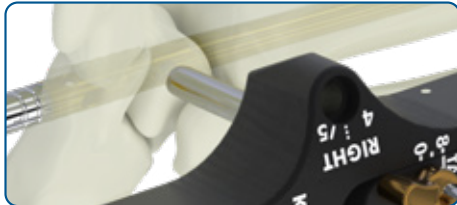

A) Unscrew the talus knob anticlockwise.

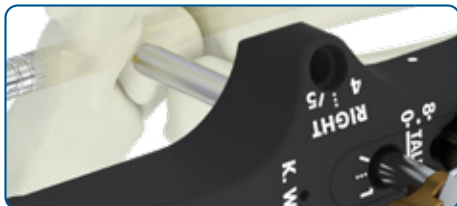

B) Translate the slider proximally to the desired position (up to 8mm) and screw the talus knob clockwise.

Ensure that an incision has been made to ensure the correct movement of the trocar.

Once the desired position has been reached, proceed with the surgical steps for placing the screw.

If the slider is positioned totally proximally (8mm) it will still be possible to perform tibio-talar apposition/compression up to 5mm.

INSTRUMENTS REQUIRED



DT030920
Cannula



DT030027
Trocar for drill bit, \varnothing 4mm

Dynamic talar screw preparation and measurement



Under fluoroscopy guidance, insert the graduated drill bit $\varnothing 4 \times 350 \text{mm}$ and drill through both cortical bones: the tip of the drill must go beyond the second cortical bone by at least 2mm.

Verify that the graduated drill bit $\varnothing 4 \times 350 \text{mm}$ passes through the nail hole both on the anterior-posterior and on the medio-lateral plane.

The correct position of the screw is in the center of the body of the talus.

Read the length of the screw directly on the shaft of the graduated drill bit at the edge of the trocar.

NOTE:

For intermediate measurements, select the shorter screw.

Remove the drill bit and the Trocar.

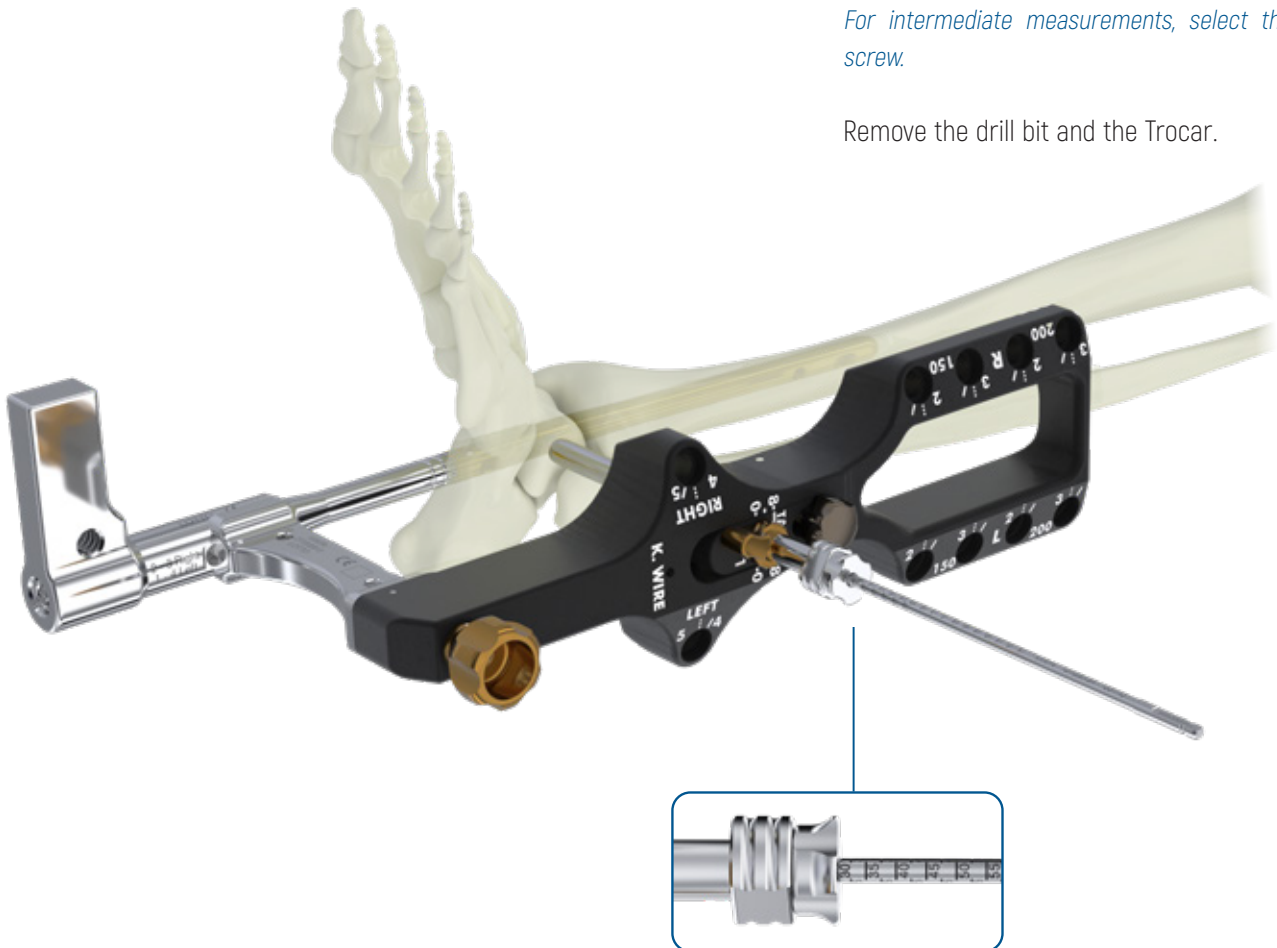

INSTRUMENTS REQUIRED

DT03013A
Graduated drill bit, $\varnothing 4 \times 350 \text{mm}$ STERILE

Use the screws ruler only with drill bit $\varnothing 4 \times 350 \text{mm}$ (DT03015A).

Measurement of the screw (optional)

Measure the screw length using the Screws ruler, making sure the Cannula is in contact with the bone. Insert the screws ruler (side of the ruler marked "trocar") onto the drill bit until it touches the trocar.



The end of the drill bit on the ruler shows the length of the screw to be implanted.

NOTE:

For intermediate measurements, select the shorter screw.

Remove the drill bit and the Trocar.

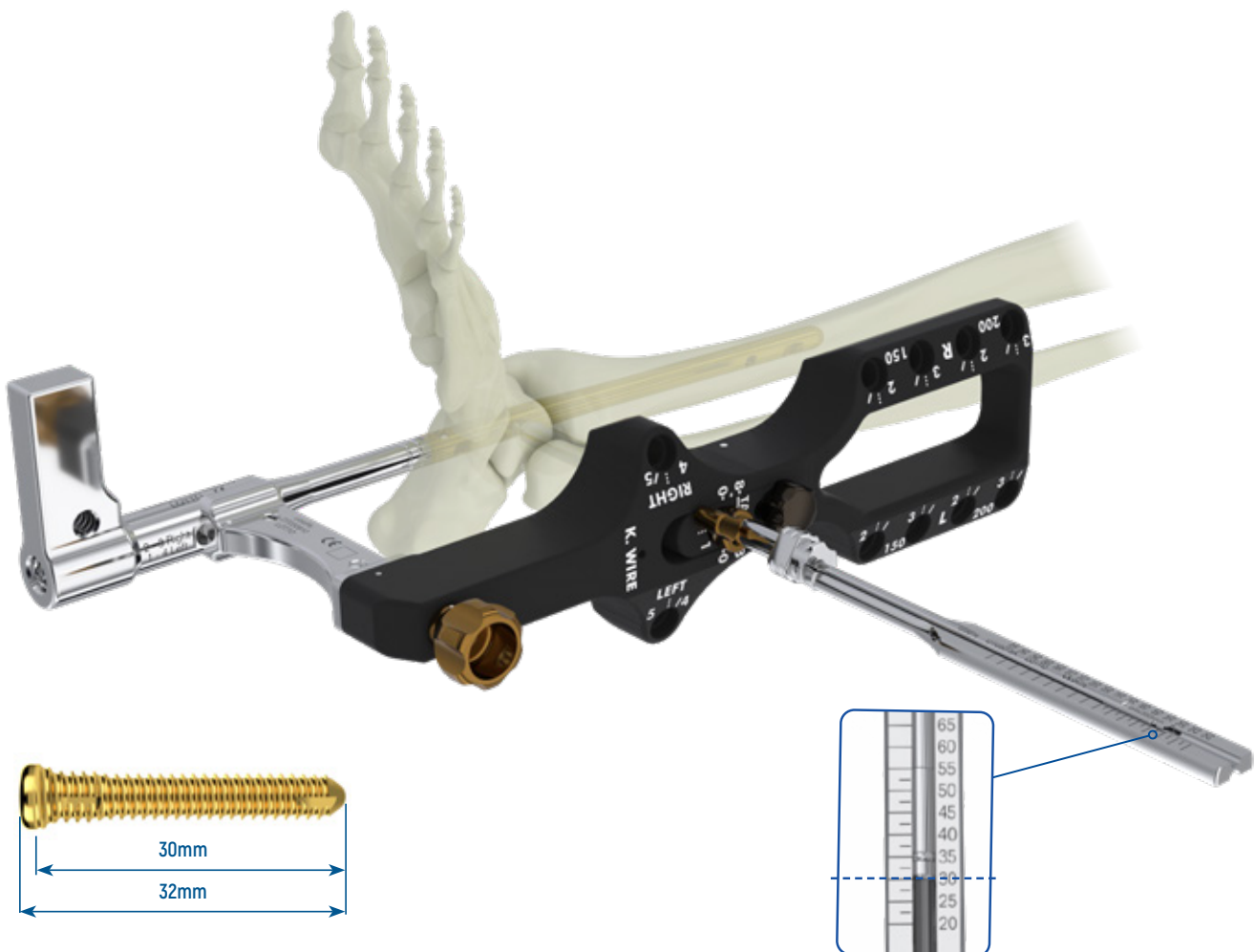

INSTRUMENTS REQUIRED



DT03015A
Drill bit, $\varnothing 4 \times 350 \text{mm}$ STERILE



DT030030
Screws ruler

Insertion of the screw



Select cortical screw $\varnothing 5.2\text{mm}$ of the measured length.

Position the screw on the Screwdriver, 5mm Hudson coupling, and assembly it manually rotating the pin clockwise.

Connect the Cannulated T-handle on the screwdriver.

Insert the screwdriver into the Cannula and screw until the "0" mark of the screwdriver reaches the edge of the Cannula.

Greater resistance may be felt during screw insertion due to the increase in diameter in the proximal portion of the screw head (0.5mm) which increases its stability.

Remove the Screwdriver, 5mm Hudson coupling, if necessary you can use the Allen wrench, 2.5mm.

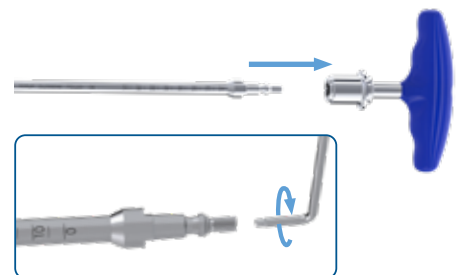

Slightly retract the cannula and check under fluoroscopy and use the hexagonal screwdriver to correct the screw's sinking if necessary.

INSTRUMENTS REQUIRED



DT030046
Screwdriver, 5mm
Hudson coupling



34.680-RAL5010
Cannulated Teardrop-handle
with Hudson coupling



DT030070
Cannulated T-handle with
Hudson coupling



970025
Allen wrench, 2.5mm



DT030943
Hexagonal Screwdriver, 5mm

PROXIMAL SCREWS



To proceed with inserting the proximal screws it is necessary to rotate the Centering Guide to the medial position and assemble it in correspondence with the marker "2 - 3 left" of the Nail Inserter.

Holes 2 and 3

Proximal screws with medial access
Only for 150mm and 200mm nails.

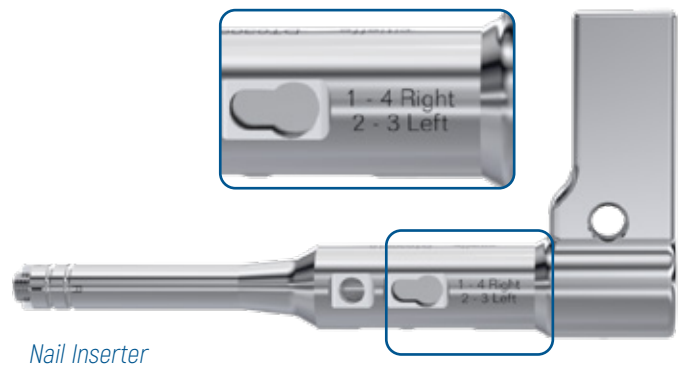

Nail Inserter

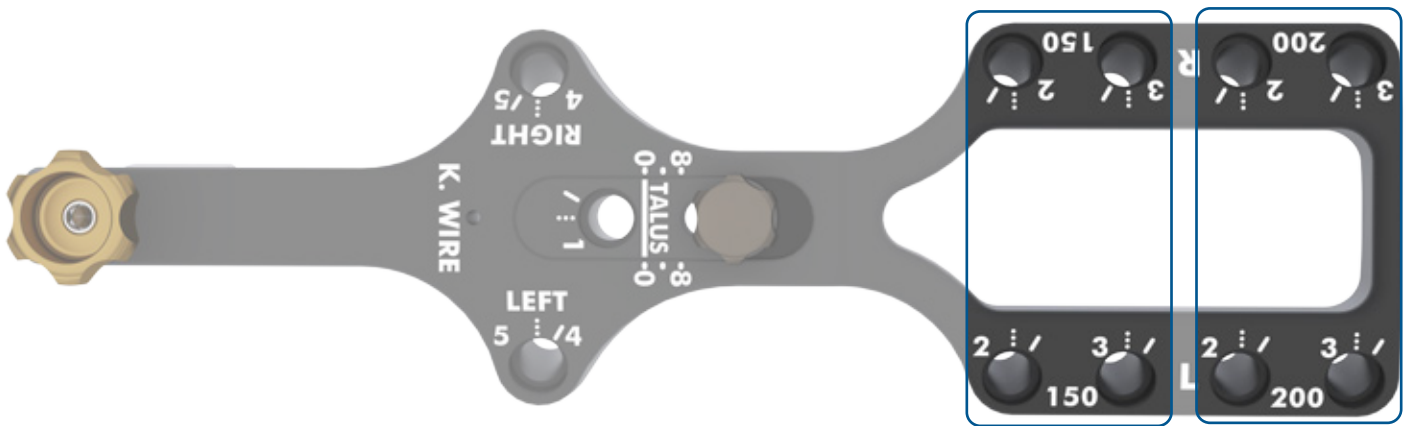

Centering guide

INSTRUMENTS REQUIRED



Nail Inserter
 (ESTREMO ankle fusion guide DT030910)



DT030910
 ESTREMO ankle fusion guide

Rotation of the centering guide

To rotate the guide:

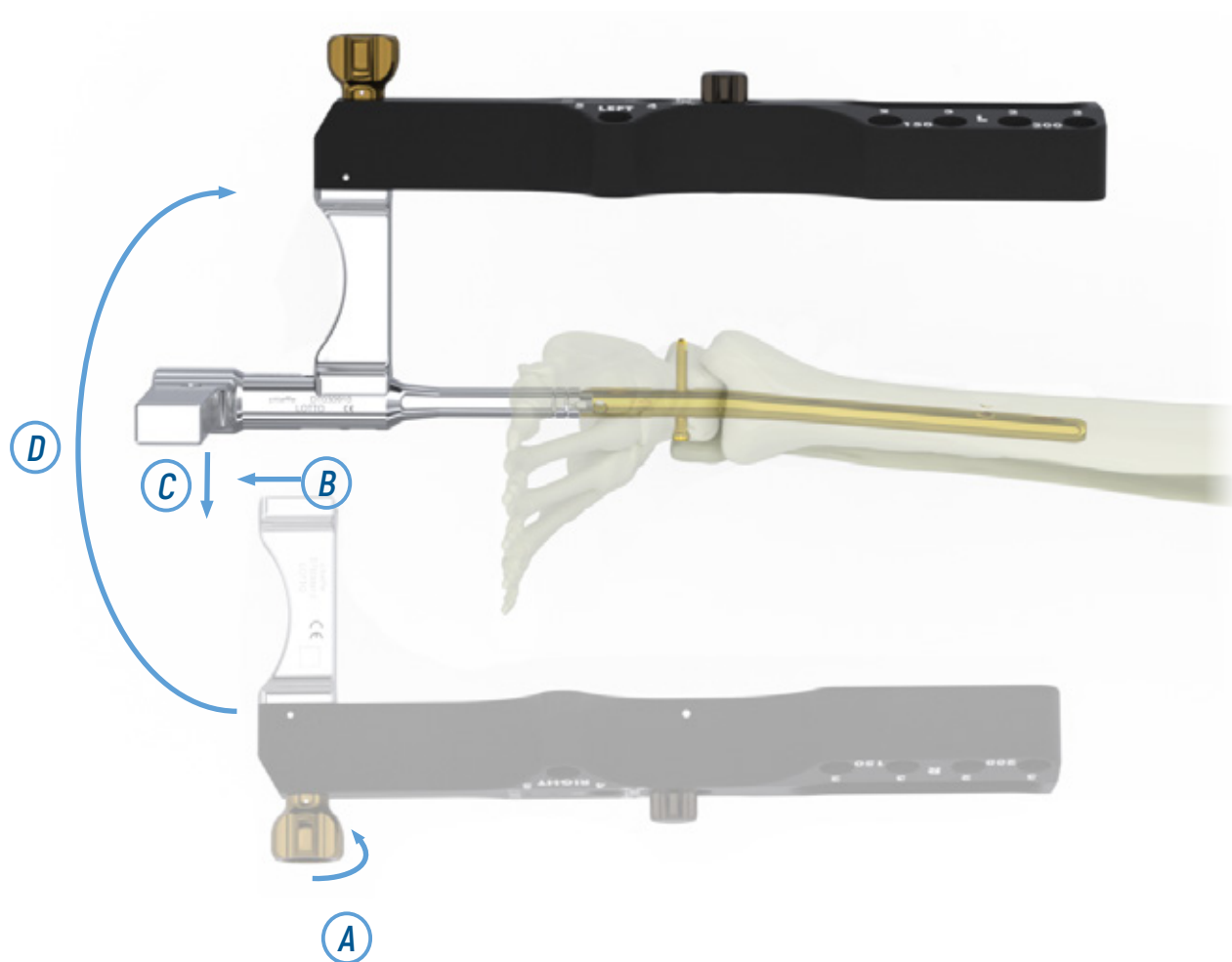

A- Unscrew the golden knob anticlockwise.

B- Move the guide distally.

C- Disengage the centering guide from the nail inserter.

D- Rotate the centering guide and assemble it to the medial position.

Rotate the guide to the medial position in correspondence with the marker 2-3 left and repeat the steps as illustrated at page 21.

INSTRUMENTS REQUIRED



Nail Inserter
(ESTREMO ankle fusion guide DT030910)



DT030910
ESTREMO ankle fusion guide

Preparation for the insertion of the static proximal screw

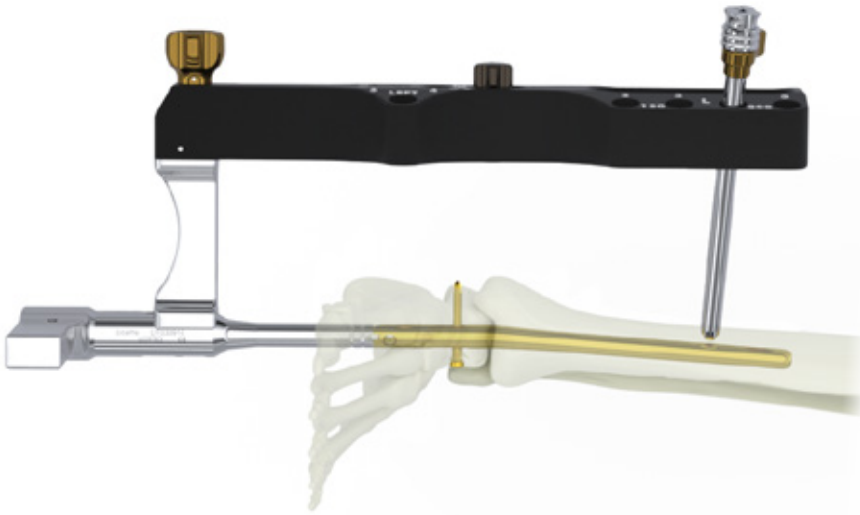

Under fluoroscopic guidance, proceed with inserting the static proximal screw in the hole of the guide marked ② (150mm nail or 200mm nail) according to the length of the implanted nail. This will allow the subsequent apposition/compression of the joint spaces.

The proximal Centering Guide only allows locking for 150mm and 200mm nails (for other lengths it is possible to lock with the freehand technique).

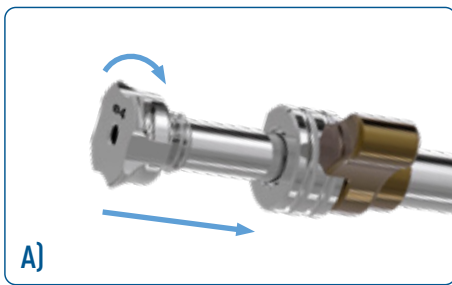

A- Insert the Trocar for drill bit into the Cannula, rotating it clockwise.



B- Locate the incision point by introducing the trocar with the Cannula into the hole marked ② and bring it into contact with the skin.

Proceed with a small incision at the tip of the trocar and rotate the cannula and the trocar through the soft tissues until they come into contact with the cortical bone.

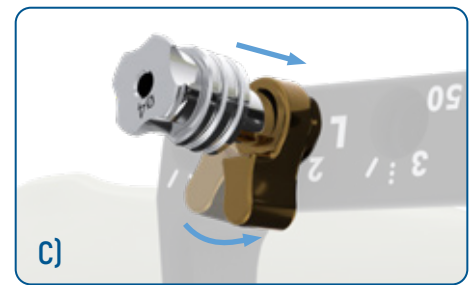

C- Bring the lever of the Cannula closer to the seat of the centering guide and rotate it to anchor the Cannula to the guide following the marker.

INSTRUMENTS REQUIRED



DT030920
Cannula



DT030027
Trocar for drill bit, \varnothing 4mm

When using the drill bit $\varnothing 4 \times 350 \text{mm}$, instead of reading the measurement directly on the graduated drill bit $\varnothing 4 \times 350 \text{mm}$, use the Screws ruler (optional step).
Follow the same steps as described at page 27.

Preparation for insertion of the static proximal screw

Under fluoroscopic guidance, insert the Graduated drill bit $\varnothing 4 \times 350 \text{mm}$ inside the trocar and drill through both cortical bones: the tip of the drill must go beyond the second cortical bone by at least 2mm.

Verify that the Graduated drill bit $\varnothing 4 \times 350 \text{mm}$ passes through the nail hole both on the anterior-posterior and on the medio-lateral plane.
Read the length of the screw directly on the shaft of the graduated drill bit at the edge of the trocar.

NOTE:

For intermediate measurements, select the shorter screw.

Remove the drill bit and the Trocar.

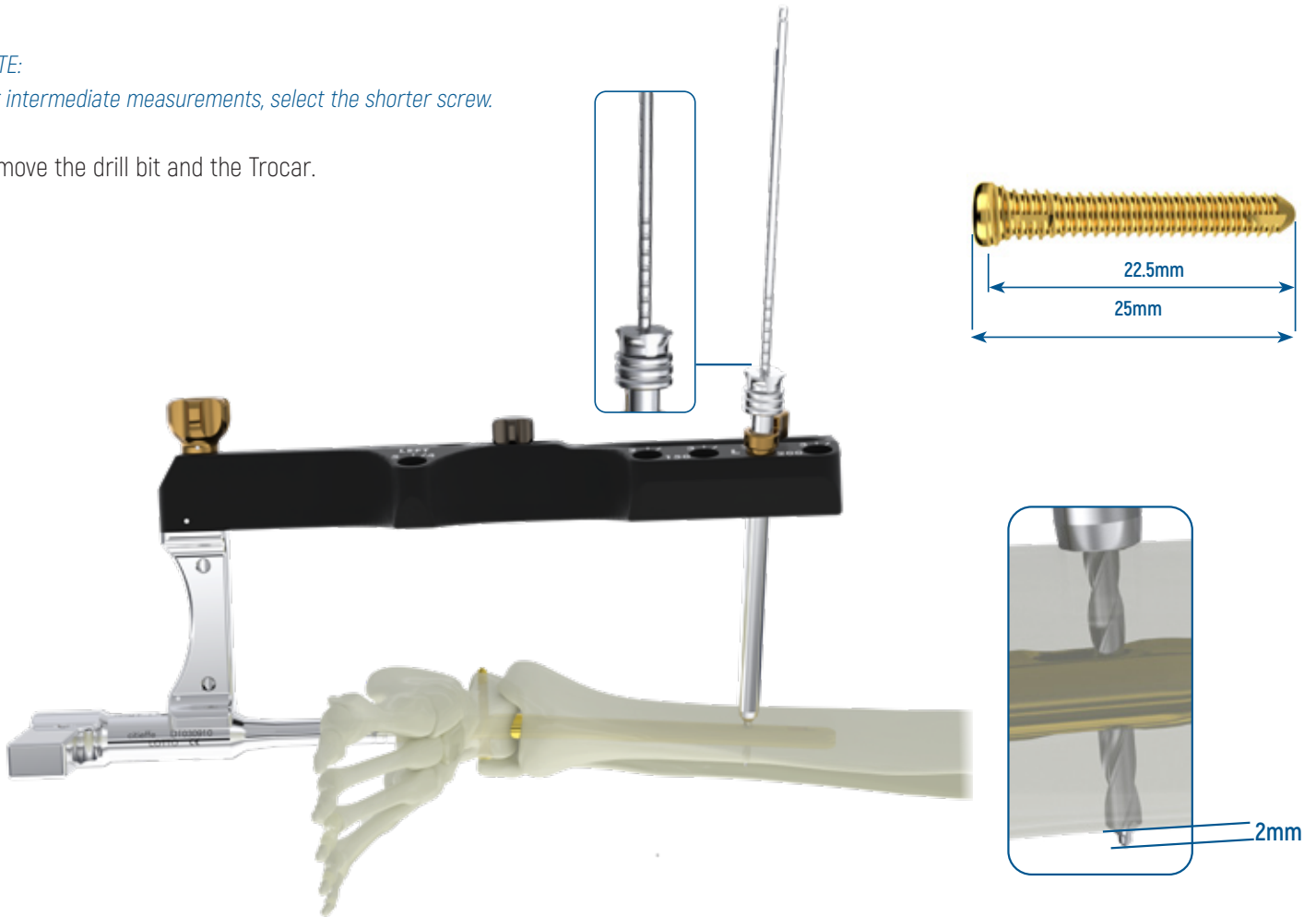

INSTRUMENTS REQUIRED



DT03013A
Graduated drill bit, $\varnothing 4 \times 350 \text{mm}$ STERILE

or



DT03015A
Drill bit, $\varnothing 4 \times 350 \text{mm}$, STERILE



DT030030
Screws ruler

Insertion of the static proximal screw

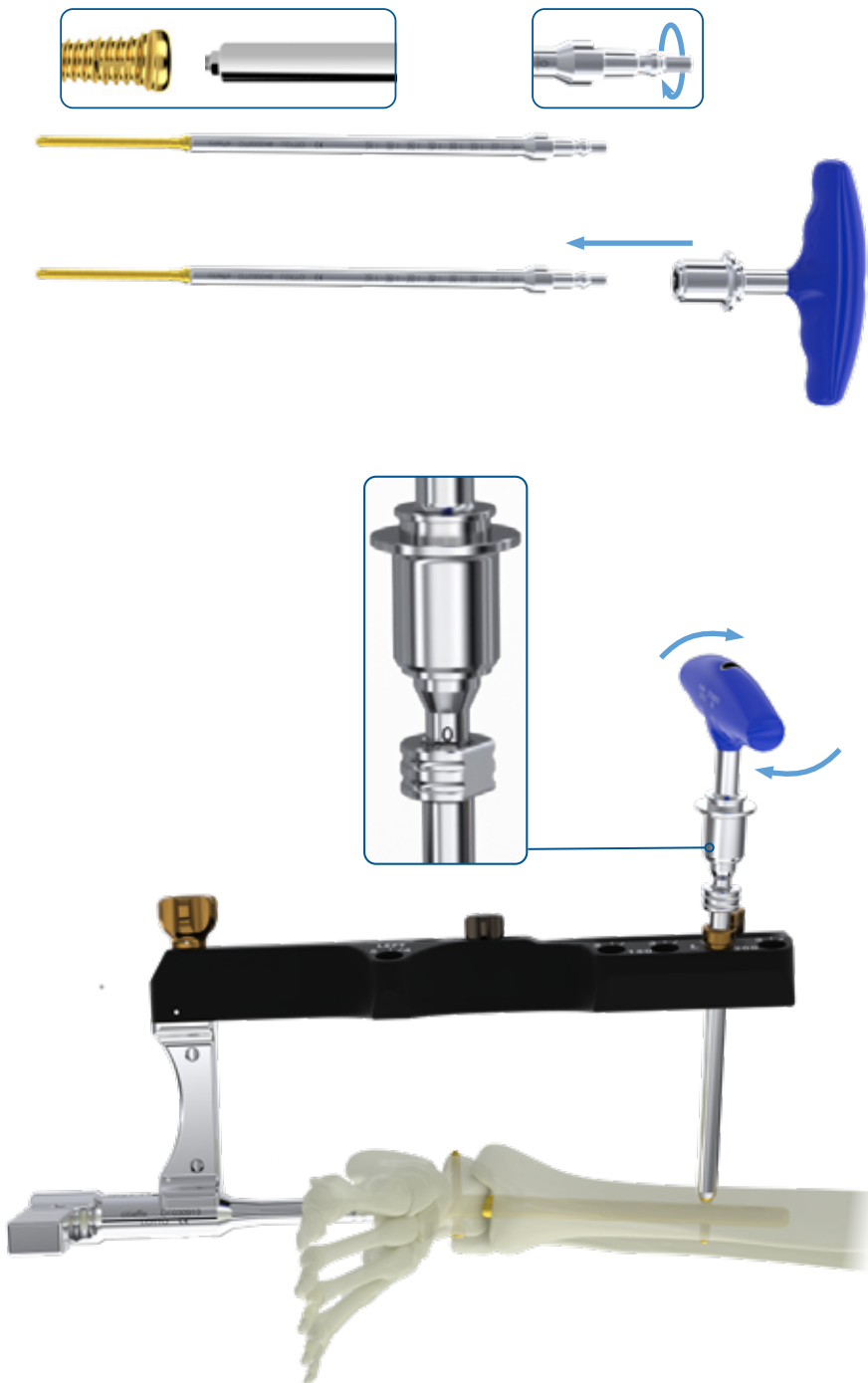

Select correct cortical screw $\varnothing 5.2\text{mm}$.
Position the screw on the Screwdriver, 5mm Hudson coupling, and assembly it manually rotating the pin clockwise.

Connect the Cannulated T-handle on the screwdriver.

Insert the screwdriver into the Cannula and screw until the "0" Marker of the screwdriver reaches the edge of the Cannula.

Greater resistance may be felt during screw insertion due to the increase in diameter in the proximal portion of the screw (0.5mm) which increases its stability.

Remove the Screwdriver, 5mm Hudson coupling, if necessary you can use the Allen wrench, 2.5mm.

Remove the cannula and the trocar.

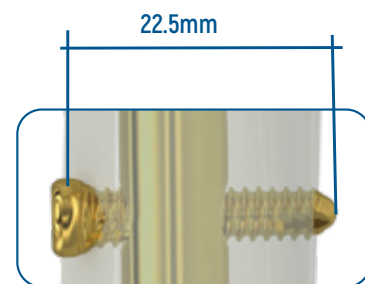

Final image of the correct screw position.

INSTRUMENTS REQUIRED



DT030046
Screwdriver, 5mm Hudson coupling



34.680-RAL5010
Cannulated Teardrop-handle with Hudson coupling

or



DT030070
Cannulated T-handle with Hudson coupling



970025
Allen wrench, 2.5mm

Insertion of the dynamic proximal screw

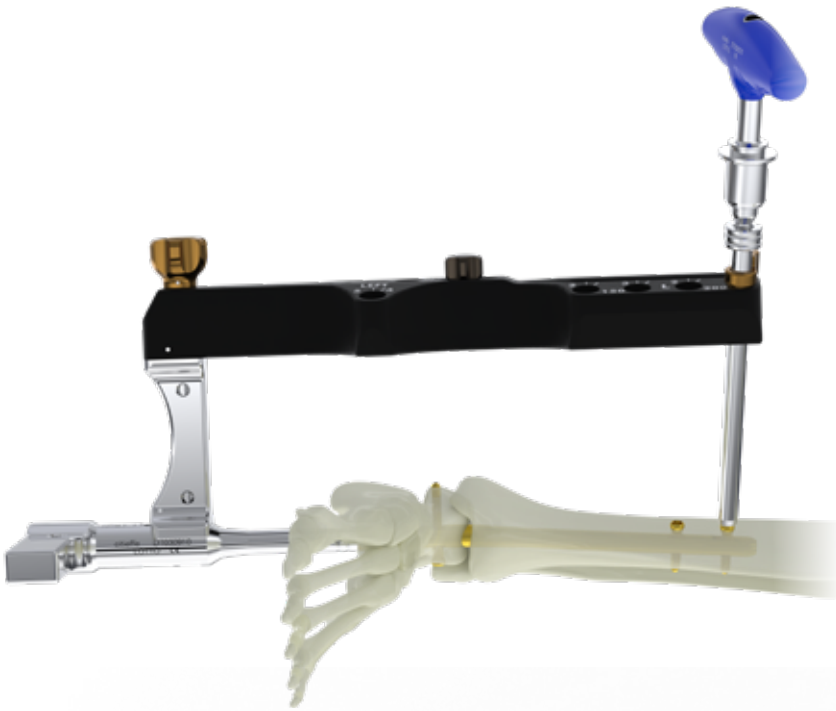

To insert the dynamic proximal screw, repeat the same steps of the static proximal screw using the hole marked ③ (150mm nail or 200mm nail) on the centering guide.

Select the $\varnothing 5.2$ mm Cortical Screw with the correct length using the Screwdriver, 5mm Hudson coupling.

Under fluoroscopic guidance, check the correct positioning of the screw in the anterior-posterior and lateral plane.

Remove the Screwdriver, 5mm Hudson coupling, if necessary you can use the Allen wrench, 2.5mm.

Remove the cannula and the trocar.

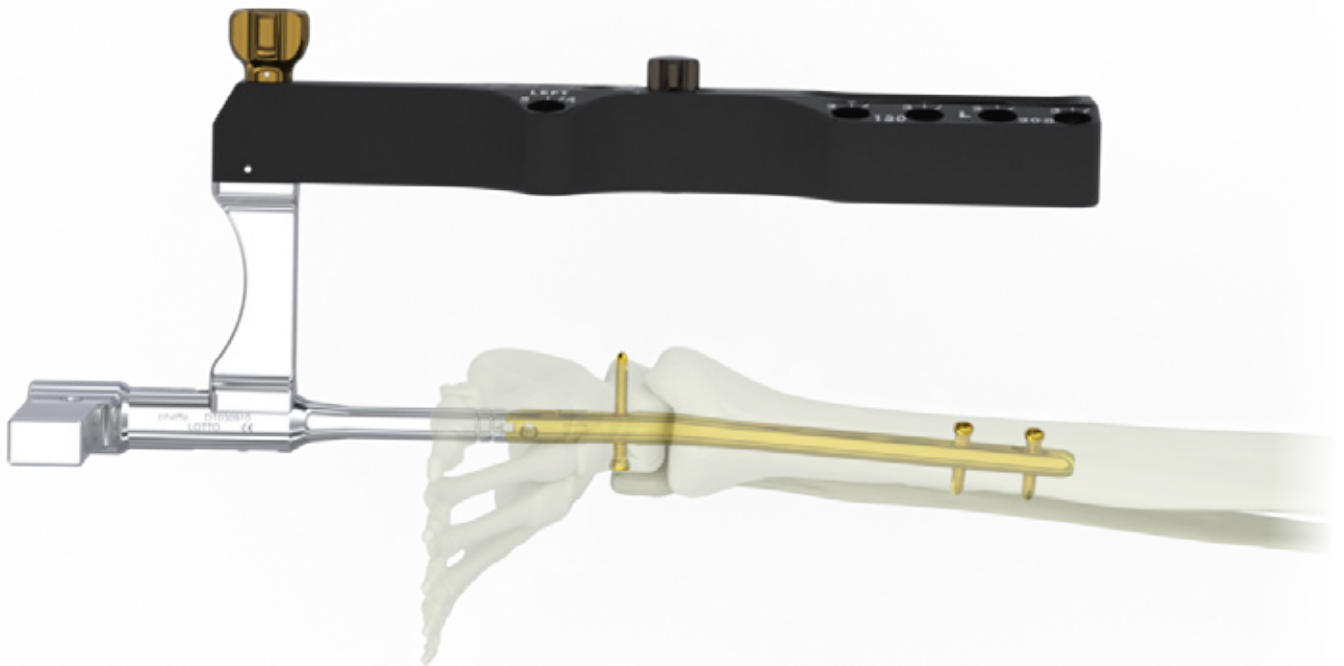

INSTRUMENTS REQUIRED



DT030046
Screwdriver, 5mm
Hudson coupling



DT030070
Cannulated T-handle with
Hudson coupling



970025
Allen wrench, 2.5mm

TIBIO-TALAR APPOSITION/COMPRESSION

Proceed with Tibio-talar apposition/compression by acting on the preassembled compression screw through the nail inserter. Depending on where are placed the talar screw, it's possible to perform an apposition/compression to a maximum of 13mm.



Assemble the 3.5mm Hexagonal screwdriver for compression with the Cannulated handle "D20" with AO coupling.

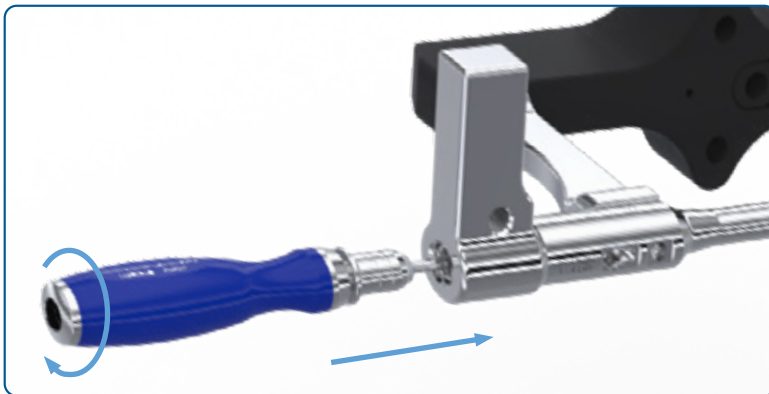
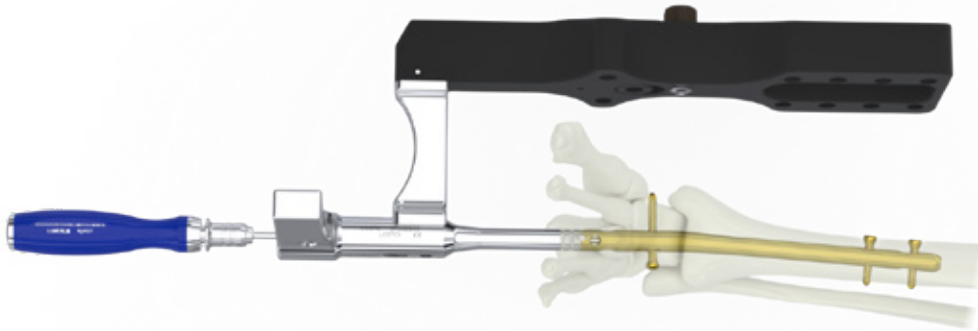

Insert the 3.5mm Hexagonal screwdriver for compression through the Nail Inserter until the tip of the screwdriver engages inside the compression screw.

Under fluoroscopic guidance, turn the screwdriver clockwise to activate the integrated mechanism. The compression screw will advance the talar screw proximally to the tibia creating apposition/compression.

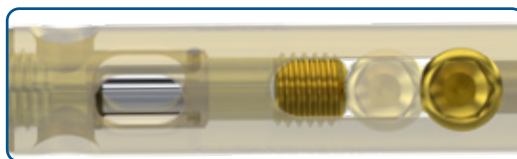

Pre compression



Post compression



INSTRUMENTS REQUIRED

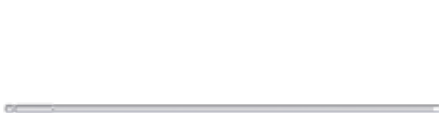

DT030941
Hexagonal screwdriver for
compression, 3.5mm

or

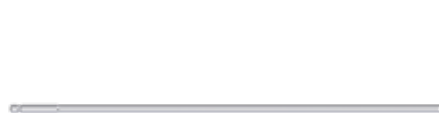

DT030942
Hexagonal screwdriver for
compression, 3.5mm STERILE



DT030971
Cannulated "D20" handle with AO coupling

LATERAL CALCANEAL SCREW

To proceed with inserting the lateral calcaneal screw it is necessary to rotate the Centering Guide to the lateral position and assemble it in correspondence with the marker "1 - 4 left" of the Nail Inserter.

Positioning this screw will allow subsequent controlled talo-calcaneal apposition/compression up to a maximum of 3mm with compression cap or with talo-calcaneal compression device



Hole 4

Insertion of the lateral calcaneal screw



Nail Inserter

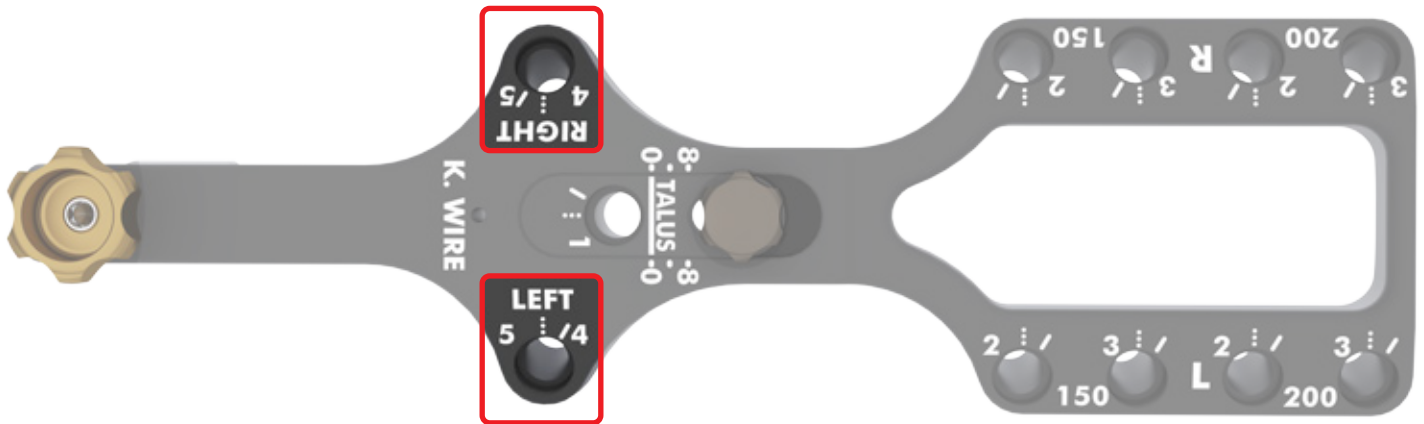

Centering guide

INSTRUMENTS REQUIRED



Nail Inserter
(ESTREMO ankle fusion guide DT030910)



DT030910
ESTREMO ankle fusion guide

Rotation of the centering guide

To rotate the guide:

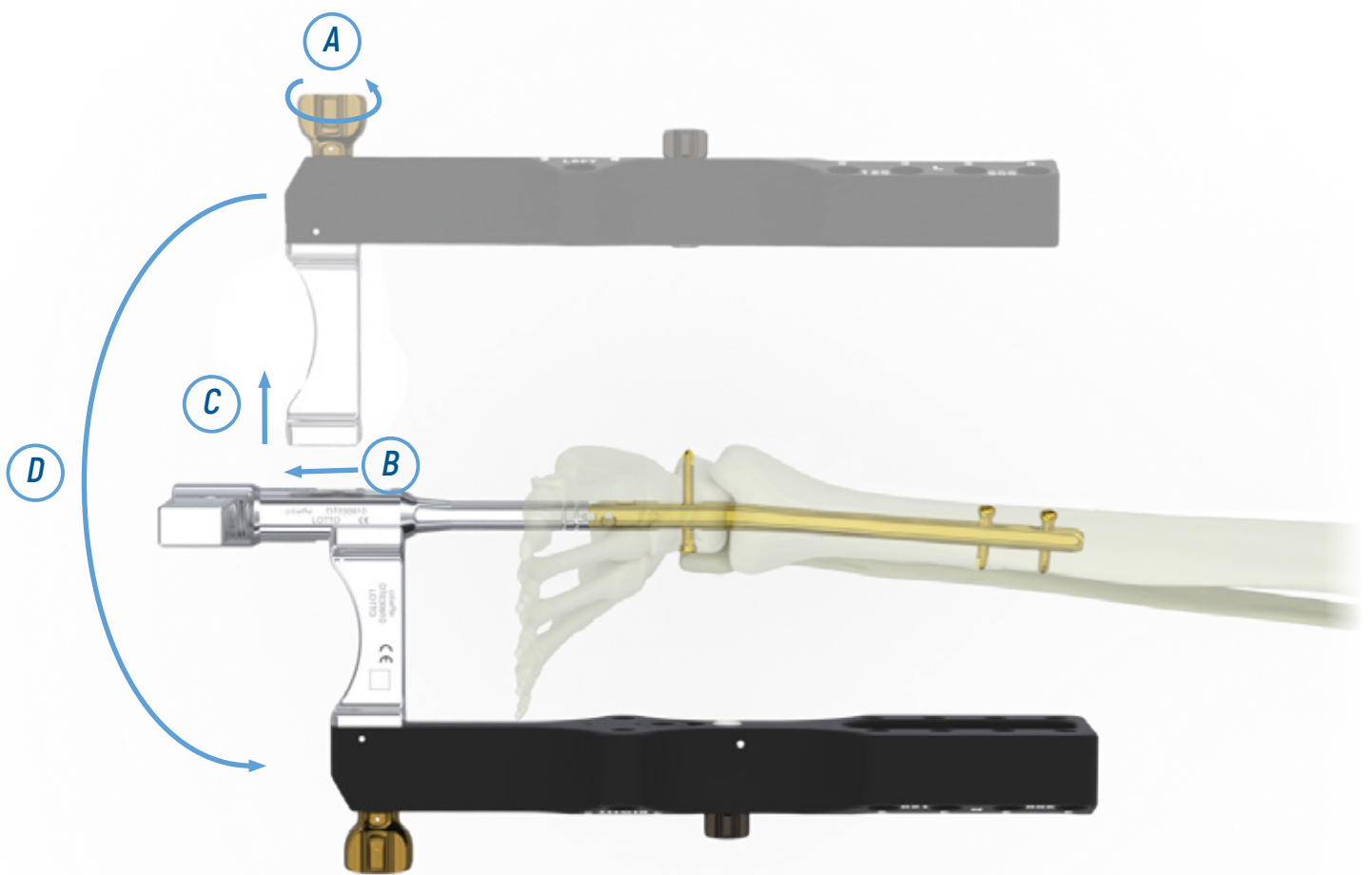

A- Unscrew the golden knob anticlockwise.

B- Move the guide distally.

C- Disengage the centering guide from the nail inserter.

D- Rotate the centering guide and assemble it to the lateral position.

Rotate the guide to the lateral position in correspondence with the marker 4 left and repeat the steps as illustrated at page 21.

INSTRUMENTS REQUIRED



Nail Inserter
[ESTREMO ankle fusion guide DT030910]



DT030910
ESTREMO ankle fusion guide

Preparation of lateral calcaneal screw



Under fluoroscopic guidance, proceed with inserting the lateral calcaneal screw in correspondence with the hole marked ④ left. Make sure the guide is in the lateral position. Positioning this screw will allow subsequent controlled talo-calcaneal apposition/compression up to a maximum of 3mm.

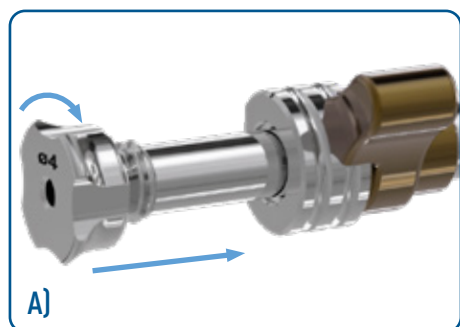

A- Insert the Trocar for drill bit into the Cannula, rotating it clockwise.



B- Locate the incision point by introducing the trocar with the cannula into the hole marked ④ left and bring it into contact with the skin.

Proceed with a small incision at the tip of the trocar and rotate the cannula and the trocar through the soft tissues until they come into contact with the cortical bone.

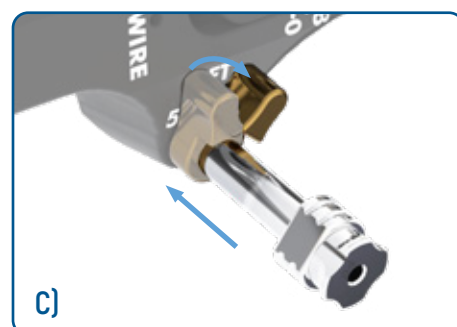

C- Bring the lever of the Cannula closer to the seat of the centering guide and rotate it to anchor the Cannula to the guide following the marker.

INSTRUMENTS REQUIRED



DT030920
Cannula



DT030027
Trocar for drill bit, \varnothing 4mm

When using the drill bit $\varnothing 4 \times 350 \text{mm}$, instead of reading the measurement directly on the graduated drill bit $\varnothing 4 \times 350 \text{mm}$, use the Screws ruler (optional step).
Follow the same steps as described at page 27.

Measurement of dynamic lateral calcaneal screw

Under fluoroscopic guidance, insert the graduated drill bit $\varnothing 4 \times 350 \text{mm}$ and drill through both cortical bones: the tip of the drill must go beyond the second cortical bone by at least 2mm.

Verify that the graduated drill bit $\varnothing 4 \times 350 \text{mm}$ passes through the nail hole both on the anterior-posterior and on the medio-lateral plane.

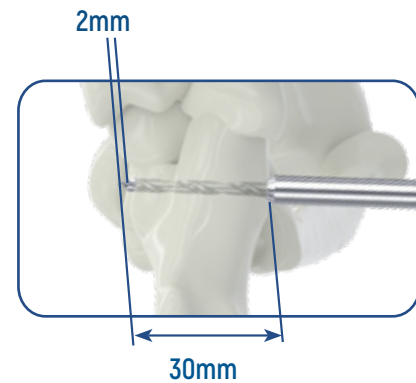

Read the length of the screw directly on the shaft of the graduated drill bit at the edge of the trocar.

NOTE:

For intermediate measurements, select the shorter screw.

Remove the drill bit and the Trocar.

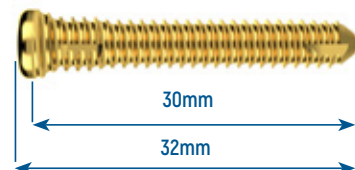
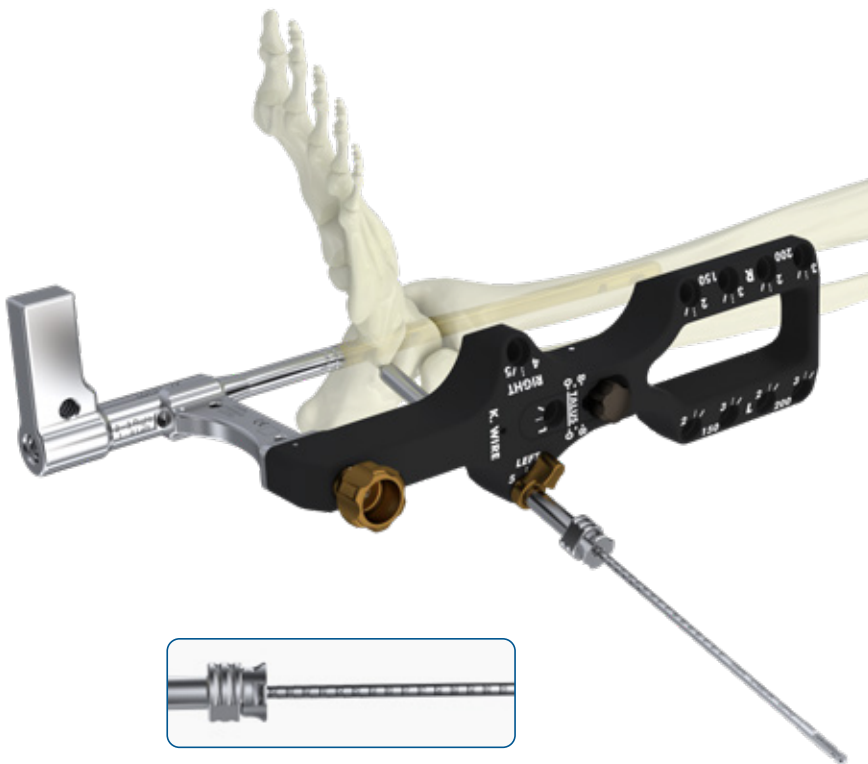

INSTRUMENTS REQUIRED



DT03013A
Graduated drill bit, $\varnothing 4 \times 350 \text{mm}$ STERILE

or



DT03015A
Drill bit, $\varnothing 4 \times 350 \text{mm}$, STERILE



DT030030
Screws ruler

Insertion of the dynamic lateral calcaneal screw

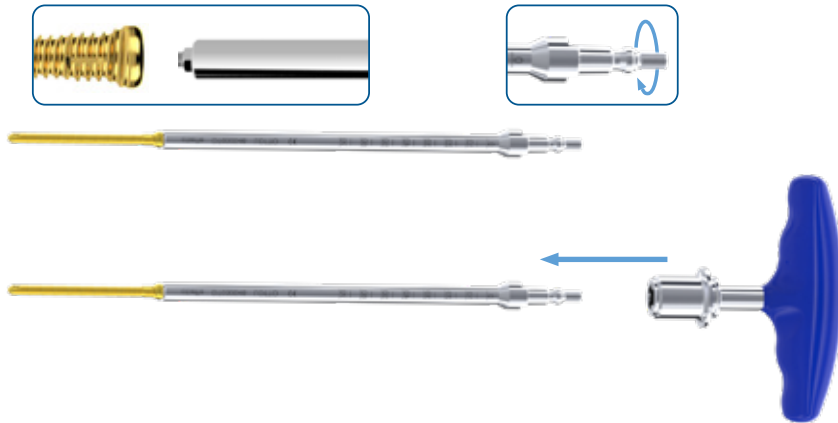

Select correct cortical screw $\varnothing 5.2\text{mm}$.

Position the screw on the Screwdriver, 5mm Hudson coupling, and assembly it manually rotating the pin clockwise.

Connect the Cannulated T-handle on the screwdriver.

Insert the screwdriver into the Cannula and screw until the "0" Marker of the screwdriver reaches the edge of the Cannula.

Under fluoroscopic guidance, check the correct positioning of the screw in the anterior-posterior and lateral plane.

Remove the Screwdriver, 5mm Hudson coupling, if necessary you can use the Allen wrench, 2.5mm.

Remove the cannula and the trocar.

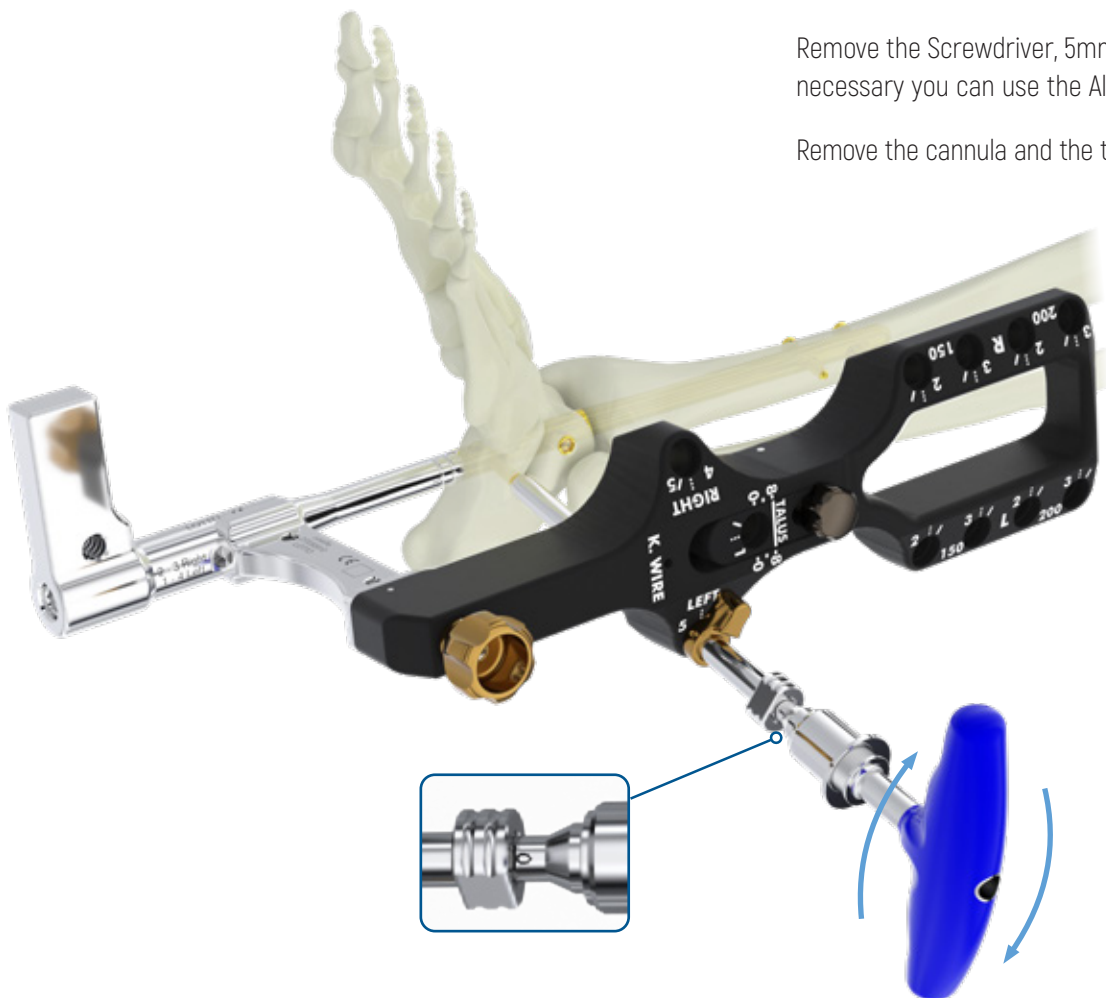

INSTRUMENTS REQUIRED



DT030046
Screwdriver, 5mm
Hudson coupling



34.680-RAL5010
Cannulated Teardrop-handle
with Hudson coupling

or



DT030070
Cannulated T-handle with
Hudson coupling



970025
Allen wrench, 2.5mm

TALO-CALCANEAL APPPOSITION/COMPRESSION (OPTIONAL)

It is possible to perform talocalcaneal apposition/compression using the methods described below.

A- Talo-calcaneal compression with compression cap



To perform Talo-calcaneal compression/apposition with the compression cap follow the steps on page 42.

In case of apposition/compression with thw compression cap it will be no longer possible to insert the posterior calcanbeal screw.



Talo-calcaneal compression cap

B- Talo-calcaneal compression with Talo-calcaneal compression device



To perform Talo-calcaneal apposition/compression with the dedicated device follow the steps on page 44.

The use of the posterior calcaneal screw is required to proceed to talo-calcaneal apposition/compression with talo-calcaneal compression device.



Talo-calcaneal compression device

A- Talo-calcaneal apposition/compression with compression cap (optional)

Preparation for Talo-calcaneal apposition/compression

In case of apposition/compression with compression cap will no longer be possible to insert the posterior calcaneal screw and the end cap.

Proceed with the removal of the Centering Guide by unscrewing the golden knob anticlockwise **(A)**, move the guide distally **(B)**, and disengage it from the Nail Inserter **(C)**.

Connect the Cannulated T-handle on the Wrench, 8mm and proceed to remove the nail inserter by unscrewing the nail connection screw anticlockwise.

Remove the Nail Inserter.

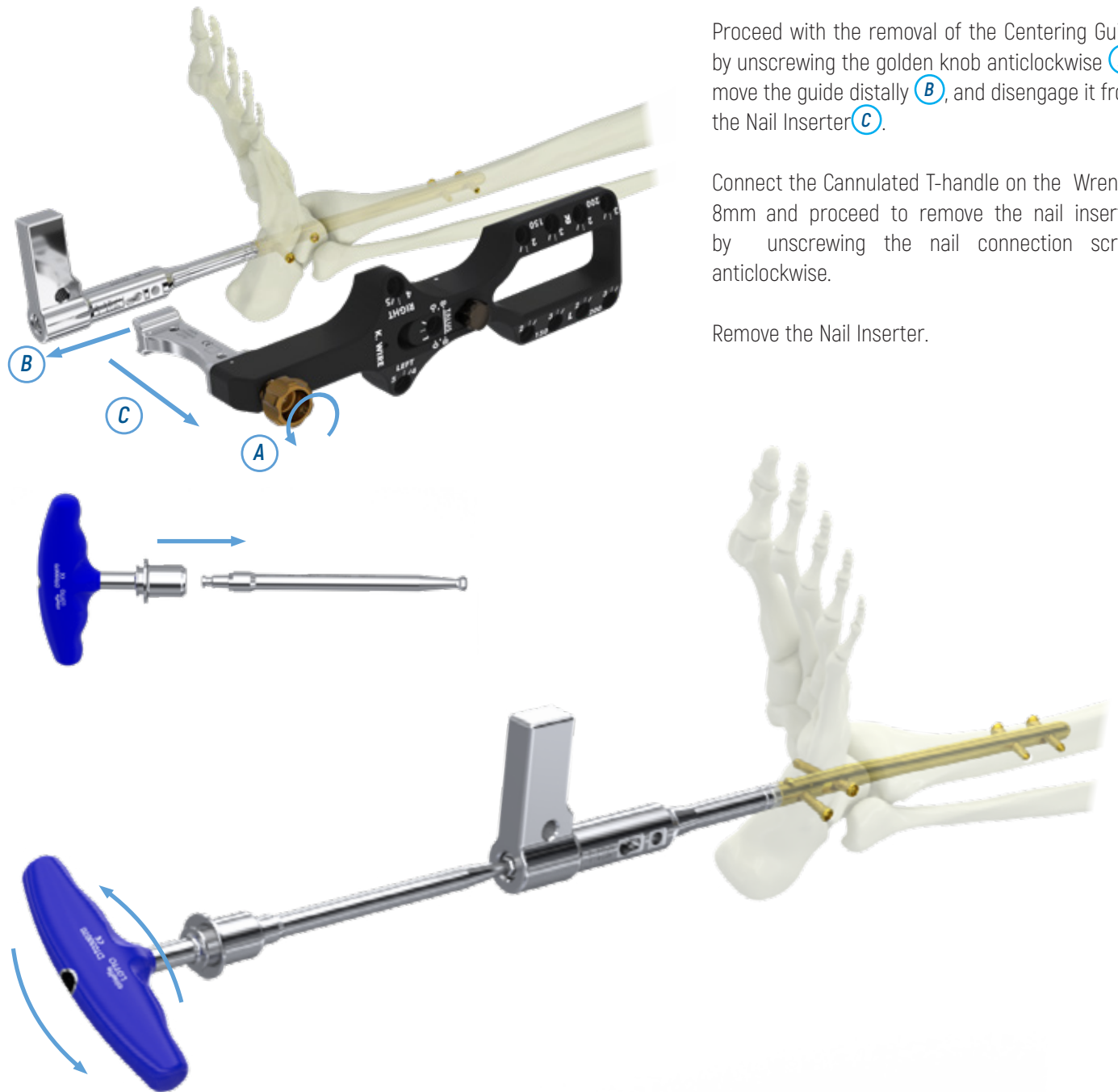

INSTRUMENTS REQUIRED



Nail Inserter
(ESTREMO ankle fusion guide DT030910)



DT030910
ESTREMO ankle fusion guide



DT030070
Cannulated T-handle with Hudson coupling



DT030045
Wrench, 8mm Hudson coupling, short

Insertion of the apposition/compression cap

After removing the guide and the Nail Inserter, proceed with inserting the compression cap with the 3.5mm Hexagonal screwdriver for compression.



Insert the compression cap inside the nail and screw clockwise until reaching the desired talo-calcaneal apposition/compression.



Pre compression



Post compression

Under fluoroscopic guidance, verify that proper compression has been achieved; an apposition/compression of up to 3mm can be obtained by moving the screw proximally.

INSTRUMENTS REQUIRED



DT030941

Hexagonal screwdriver for
compression, 3.5mm

or



DT030942

Hexagonal screwdriver for
compression, 3.5mm STERILE



DT030971

Cannulated "D20" handle with AO coupling

B- Talo-calcaneal apposition/compression with TALO-CALCANEAL compression device (optional)

The use of the posterior calcaneal screw is required to proceed to talo-calcaneal apposition/compression with talo-calcaneal compression device.

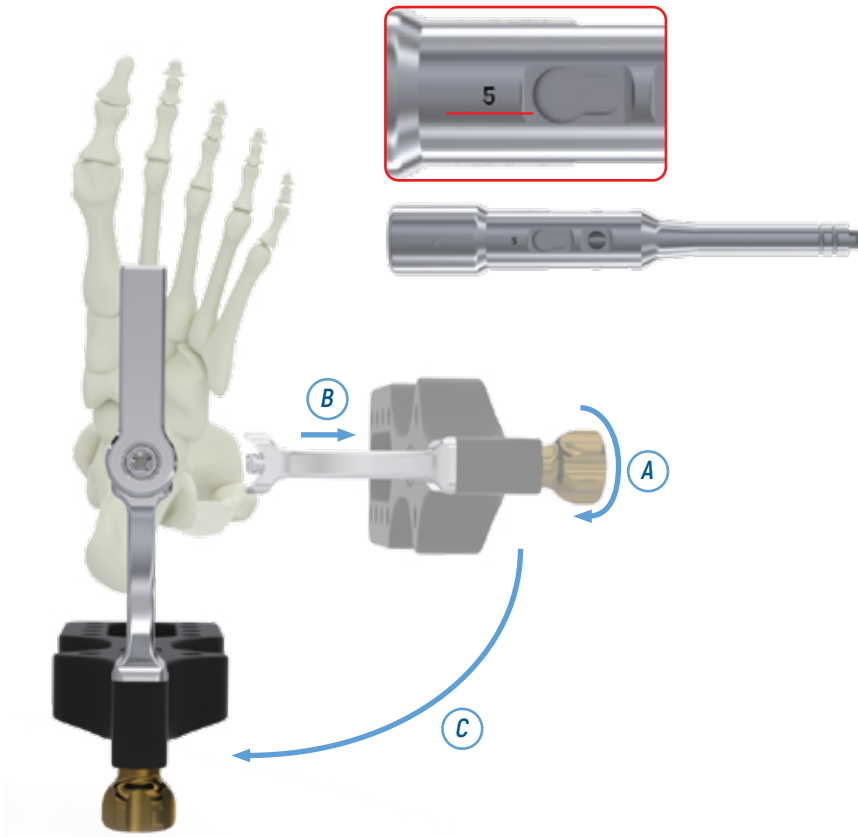

To proceed with talo-calcaneal apposition/compression with the dedicated device it is necessary to rotate the Centering Guide to the posterior position and assemble it in correspondence with the marker ⑤ of the Nail Inserter.

Unscrew the golden knob anticlockwise ①, move the guide distally and disengage it from the nail inserter. ②

Rotate the guide to the posterior position ③ and repeat the steps used to assemble the guide to other screw.

In the following steps it will be possible to use the hole marked ① on the centering guide to introduce the guide wire and the hole marked ⑤ on the centering guide to introduce the posterior calcaneal screw.

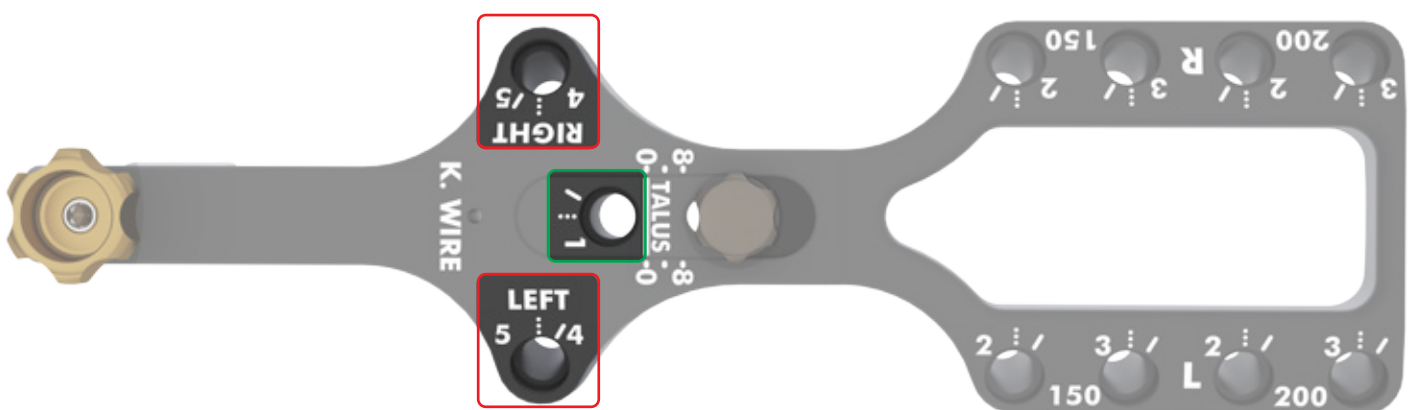

INSTRUMENTS REQUIRED



Nail Inserter
[ESTREMO ankle fusion guide DT030910]



DT030910
ESTREMO ankle fusion guide

Talo-calcaneal apposition/compression

Introduce the Compression device into the nail inserter.

Under fluoroscopic guidance, turn the Compression device clockwise to check apposition/ compression progress.

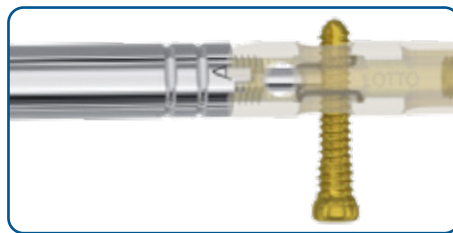
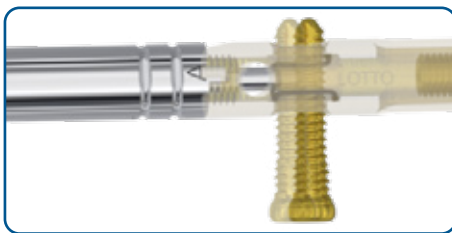
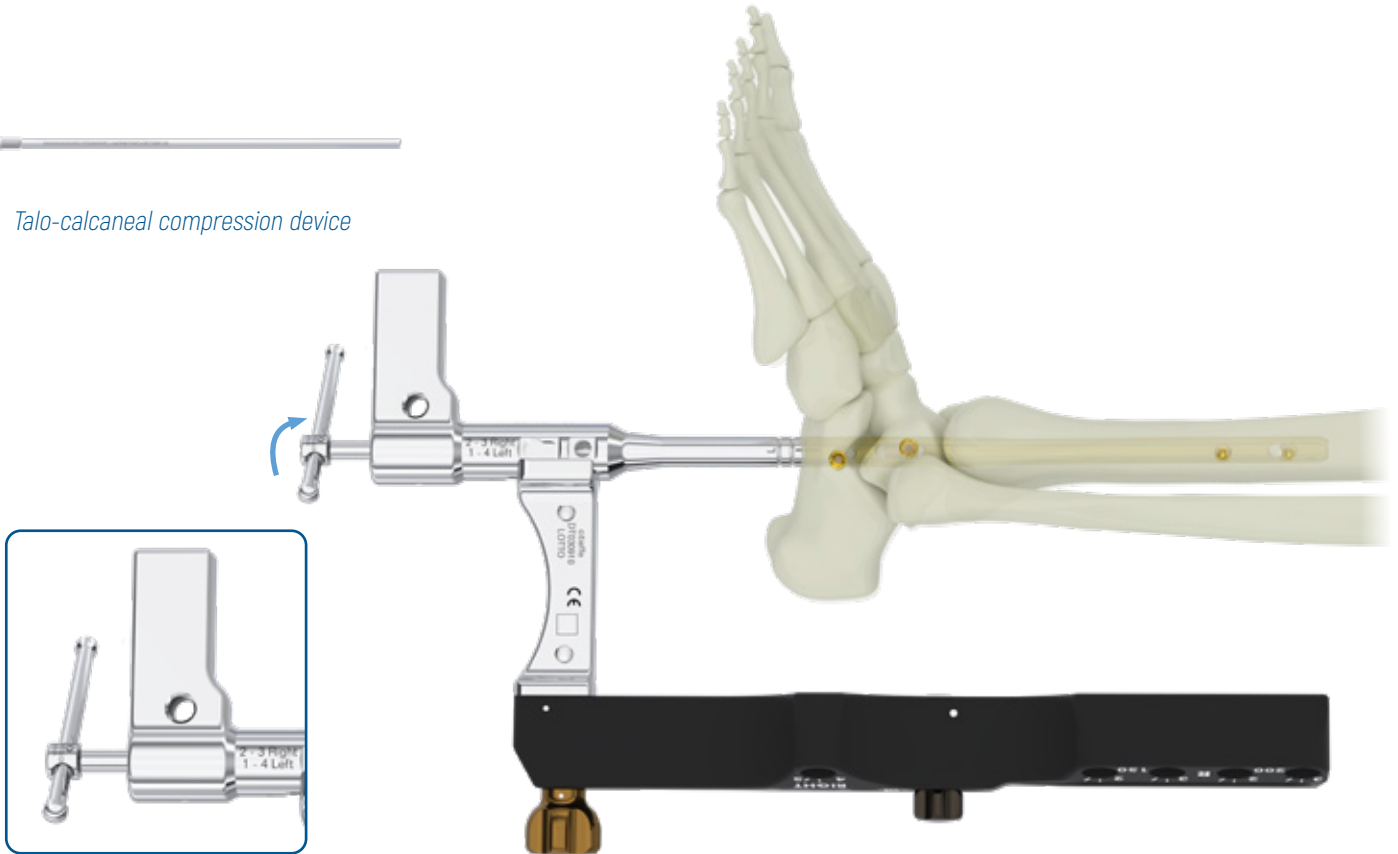
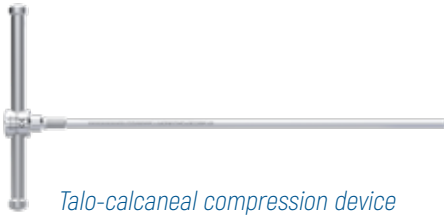

INSTRUMENTS REQUIRED



DT030952
Talo-calcaneal compression
device

Compression stabilization with guide wire

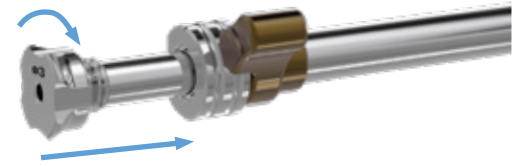

Insert the trocar $\varnothing 3\text{mm}$ into the cannula rotating it clockwise. Insert them in the hole marked ① and bring it into contact with the skin.

Bring the lever of the cannula closer to the seat of the centering guide and rotate the lever to anchor the cannula to guide.

Insert Guide wire, trocar tip $\varnothing 3 \times 350\text{mm}$ and drill to the deirdered lenght, this wire maintaining the compression obtained.

Unscrew the compression device anticlockwise to remove it.

Follow the steps for inserting the posterior calcaneal screw as described on page 49.

NOTE:

Can be achieve talo-calcaneal compression up to a maximum of 3mm.

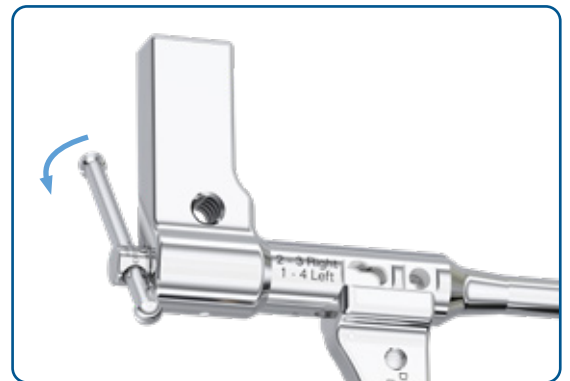

INSTRUMENTS REQUIRED



DT030920
Cannula



DT030025
Trocar $\varnothing 3\text{mm}$



66987
Guide wire, trocar tip $\varnothing 3 \times 350\text{mm}$, STERILE



DT030952
Talo-calcaneal compression device

POSTERIOR CALCANEAL SCREW

The posterior calcaneal screw can be inserted without performing talo-calcaneal apposition/compression.

To proceed with inserting the posterior calcaneal screw it is necessary to rotate the Centering Guide to the medial position and assemble it in correspondence with the marker "5" of the Nail Inserter.

In case of apposition/compression with compression cap will no longer be possible to insert the posterior calcaneal screw.

Hole 5

Insertion of the posterior calcaneal screw



Nail Inserter

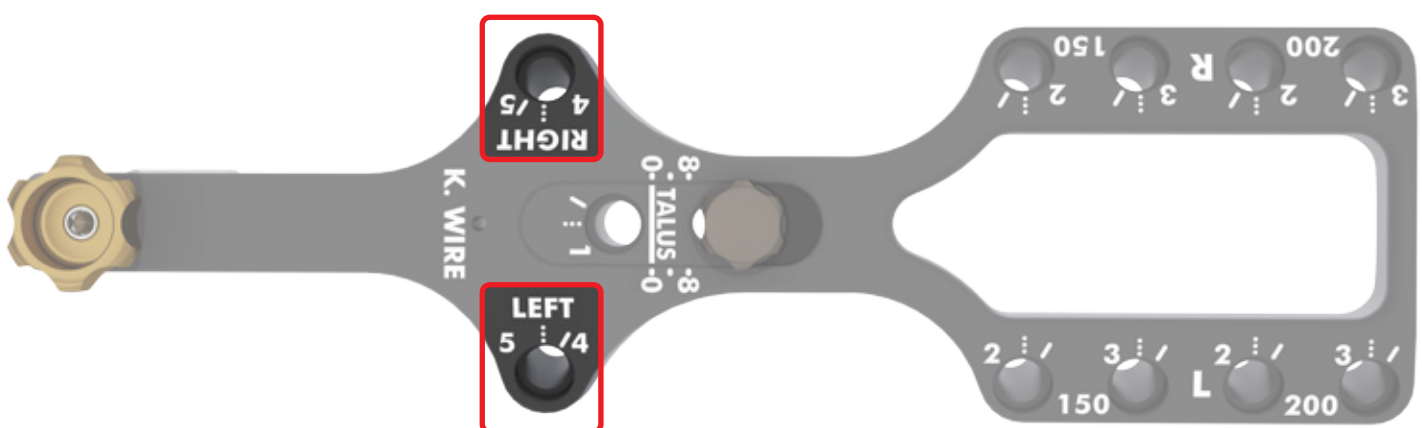

Centering guide

INSTRUMENTS REQUIRED



Nail Inserter

(ESTREMO ankle fusion guide DT030910)



DT030910

ESTREMO ankle fusion guide

Rotation of the centering guide

To rotate the guide:

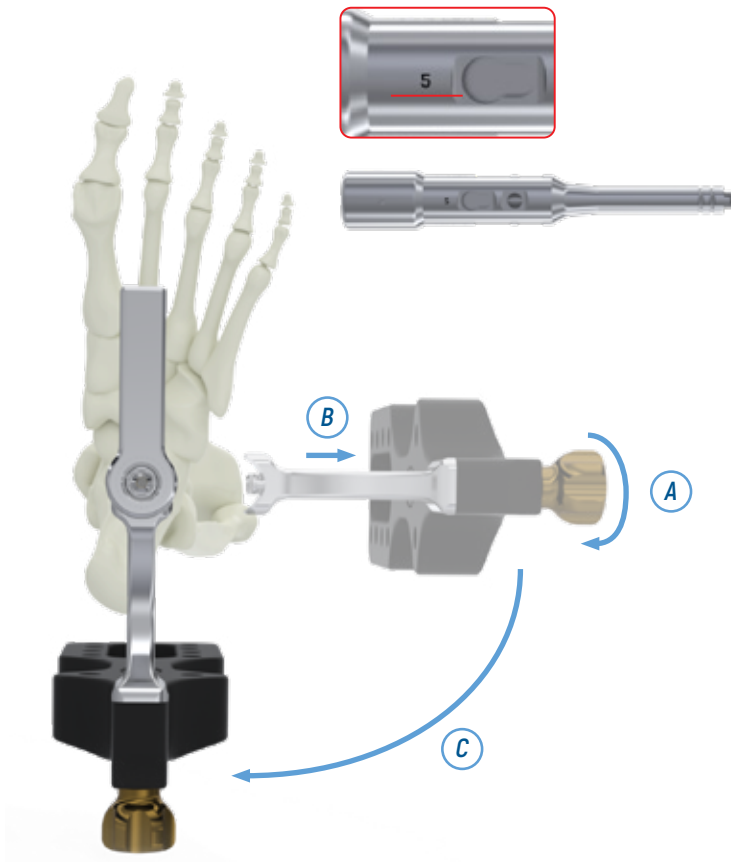

To proceed with the insertion of the posterior calcaneal screw, rotate the Centring Guide to the posterior position and attach it to the "5" mark on the Screw Insertor.

Unscrew the gold knob anticlockwise (A), move the guide distally and detach it from the Screw Insertor. (B)

Rotate the guide to the posterior position (C) and repeat the steps used to assemble the guide shown on page 21.

In the following steps, you can use the hole marked ① on the centring guide to insert the guide wire and the hole marked ⑤ on the centring guide to insert the posterior calcaneal screw.

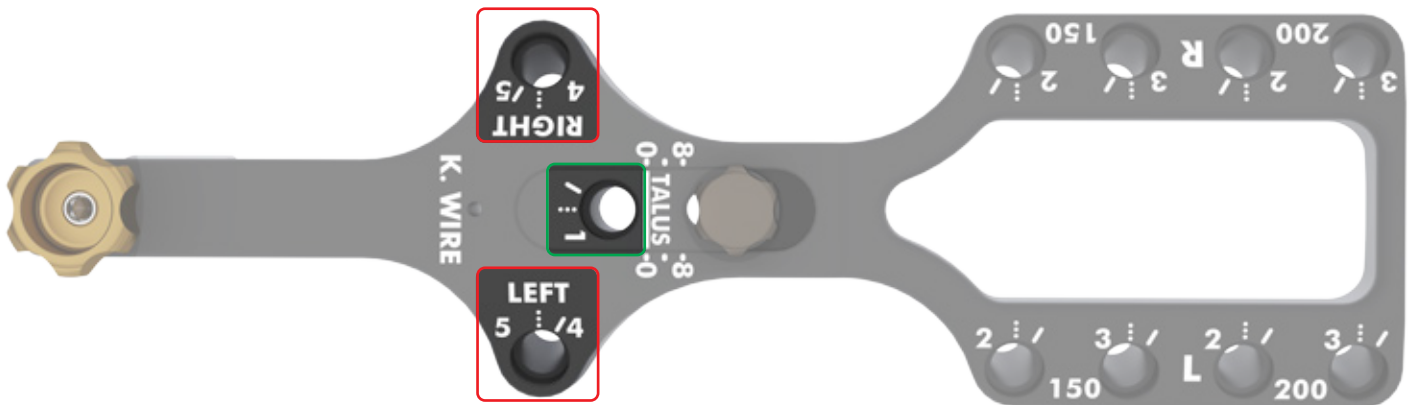

INSTRUMENTS REQUIRED



DT030910

Estremo ankle fusion guide

Preparation of posterior calcaneal screw



The following steps can also be performed without the introduction of the stabilization guide wire.

Under fluoroscopic guidance, proceed with inserting the posterior calcaneal screw in correspondence with the hole marked ⑤ left. Make sure the guide is in the posterior position.

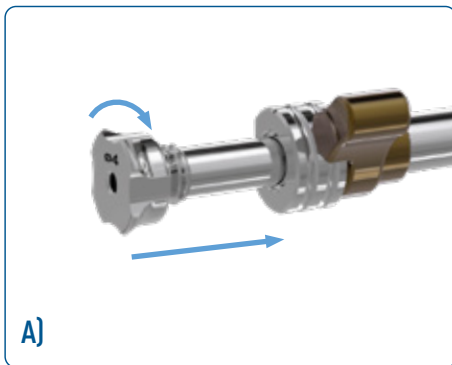

A)

A- Insert the Trocar for drill bit into the Cannula, rotating it clockwise.

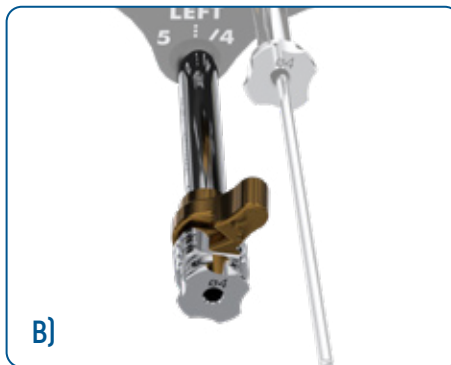

B)

B- Locate the incision point by introducing the trocar with the cannula into the hole marked ⑤ left and bring it into contact with the skin. Proceed with a small incision at the tip of the trocar and rotate the cannula and the trocar through the soft tissues until they come into contact with the cortical bone.

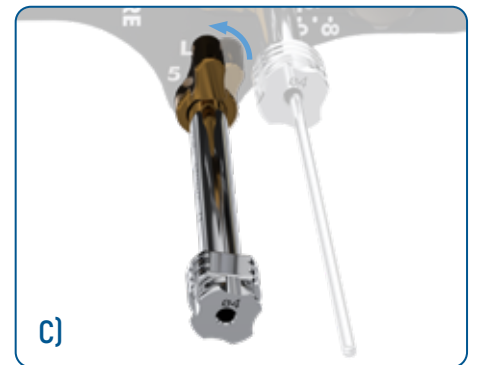

C)

C- Bring the lever of the Cannula closer to the seat of the centering guide and rotate it to anchor the Cannula to the guide following the marker.

INSTRUMENTS REQUIRED



DT030920
Cannula



DT030027
Trocar for drill bit \varnothing 4mm

When using the drill bit $\varnothing 4 \times 350 \text{mm}$, instead of reading the measurement directly on the graduated drill bit $\varnothing 4 \times 350 \text{mm}$, use the Screws ruler (optional step).
Follow the same steps as described at page 27.

Preparation of the posterior calcaneal screw

Under fluoroscopic guidance Insert the graduated drill bit $\varnothing 4 \times 350 \text{mm}$ and drill to the desired length.

Verify that the Graduated drill bit $\varnothing 4 \times 350 \text{mm}$ passes through the nail hole both on the anterior-posterior and on the medio-lateral plane.

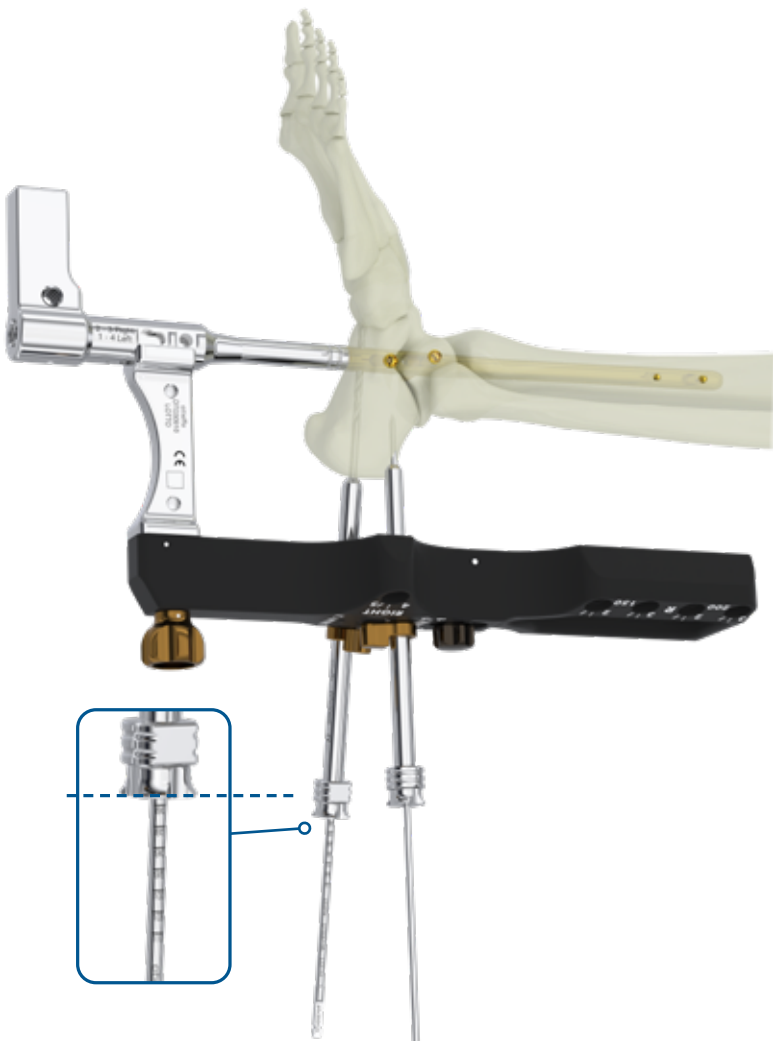

Read the length of the screw directly on the shaft of the graduated drill bit at the edge of the trocar.

NOTE:
For intermediate measurements, select the shorter screw.

Remove the drill bit and the Trocar.

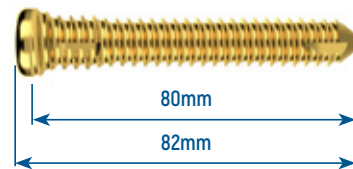

INSTRUMENTS REQUIRED



DT03013A
Graduated drill bit, $\varnothing 4 \times 350 \text{mm}$ STERILE

or



DT03015A
Drill bit, $\varnothing 4 \times 350 \text{mm}$, STERILE



DT030030
Screws ruler

Insertion of the posterior calcaneal screw

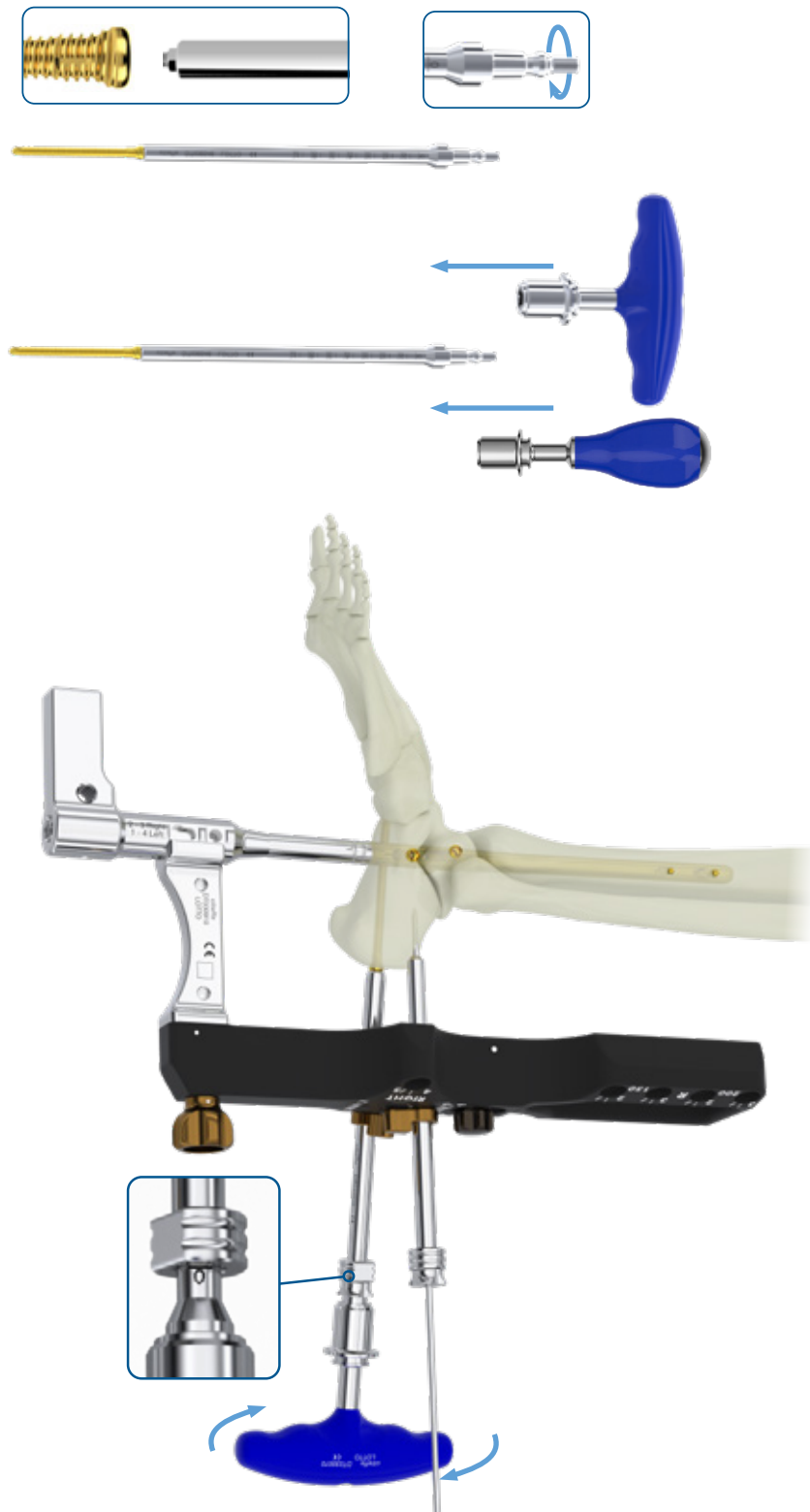

Select cortical screw $\varnothing 5.2\text{mm}$ of the measured length.

Position the screw on the Screwdriver, 5mm Hudson coupling, and assembly it manually rotating the pin clockwise.

Connect the Cannulated T-handle or the Cannulated Teardrop-handle with Hudson coupling on the screwdriver.

Note:

When using a guide wire, the cannulated teardrop handle with Hudson connector can be used to facilitate insertion.

Insert the screwdriver into the cannula and screw until the "0" Marker of the screwdriver reaches the edge of the cannula.

Greater resistance may be felt during screw insertion due to the increase in diameter in the proximal portion of the screw (0.5mm) which increases its stability.

Remove the Screwdriver, 5mm Hudson coupling, if necessary you can use the Allen wrench, 2.5mm.

Remove the guide wire if inserted.
Remove the cannulas and the trocars.

INSTRUMENTS REQUIRED



DT030046
Screwdriver, 5mm Hudson coupling



34.680-RAL5010
Cannulated Teardrop-handle with Hudson coupling

or



DT030070
Cannulated T-handle with Hudson coupling



970025
Allen wrench, 2.5mm

CENTERING GUIDE REMOVAL

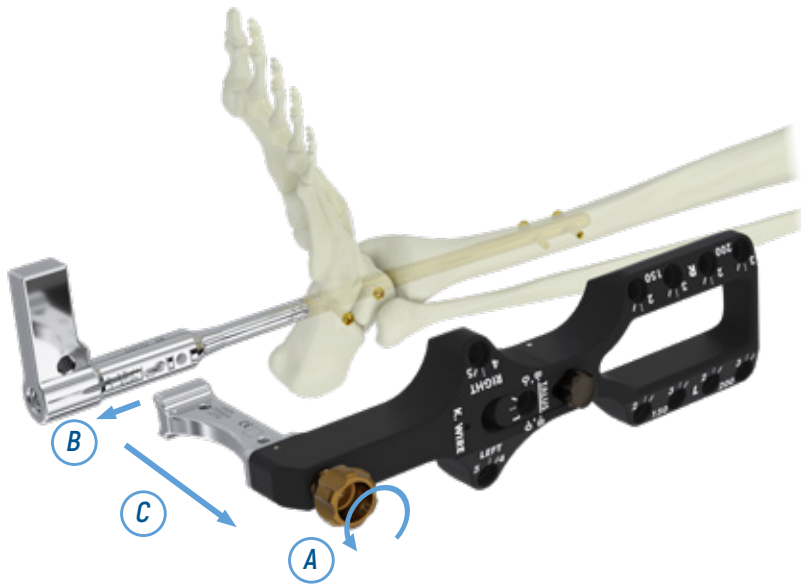

Proceed with the removal of the Centering Guide by unscrewing the golden knob anticlockwise (A), move the guide distally (B), and disengage it from the Nail Inserter (C).

Connect the Cannulated T-handle on the wrench, 8mm and proceed to remove the nail inserter by unscrewing the nail connection screw anticlockwise.

Remove the Nail Inserter.

NOTE:

Before removing the guide under fluoroscopic guidance, note the reference mark on the nail inserter to select the correct length cap.

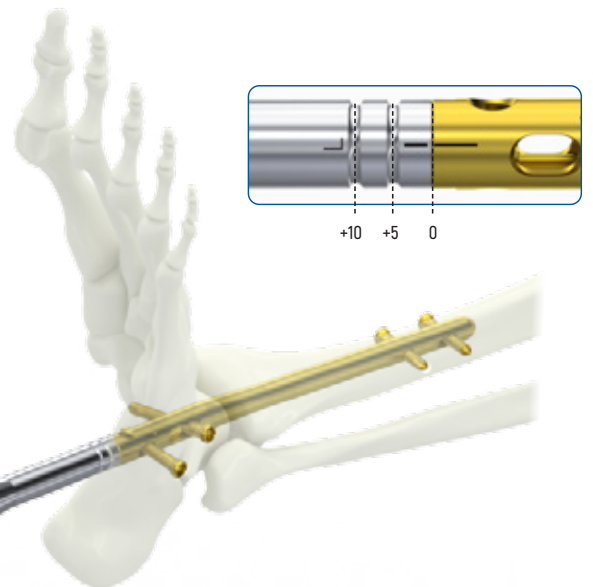

INSTRUMENTS REQUIRED



DT030070
Cannulated T-handle with Hudson coupling



DT 030045
wrench, 8mm Hudson coupling, short

INSERTION OF THE END CAP

In case the compression cap has been inserted it will no longer be possible to insert the end cap.



Code	L.
DT360000	0 mm
DT360005	5 mm

Select the correct length of the end cap.

Position the end cap on the Screwdriver, 5mm Hudson coupling, and assembly it manually rotating the pin clockwise.

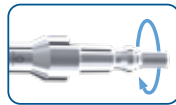
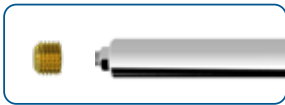

Insert the end cap inside the nail and rotate it clockwise.

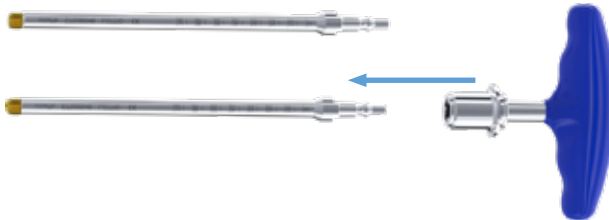

Remove the Screwdriver, 5mm Hudson coupling, if necessary you can use the Allen wrench, 2.5mm.

NOTE:

If the Posterior calcaneal screw has been implanted, the end cap (0mm or 5mm) locks this screw, enhancing the stability of the implant.



INSTRUMENTS REQUIRED



DT030046
Screwdriver, 5mm
Hudson coupling

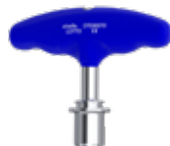

DT030070
Canulated T-handle with
Hudson coupling



970025
Allen wrench, 2.5mm

ORDERING INFORMATION

TITANIUM

STERILE



ESTREMO Ankle Fusion Nail



LEFT

ø10 mm

Code	L. mm
DT361015	150
DT361020	200
DT361025	250
DT361030	300

ø11 mm

Code	L. mm
DT361115	150
DT361120	200
DT361125	250
DT361130	300

ø12 mm

Code	L. mm
DT361215	150
DT361220	200
DT361225	250
DT361230	300

RIGHT

ø10 mm

Code	L. mm
DT371015	150
DT371020	200
DT371025	250
DT371030	300

ø11 mm

Code	L. mm
DT371115	150
DT371120	200
DT371125	250
DT371130	300

ø12 mm

Code	L. mm
DT371215	150
DT371220	200
DT371225	250
DT371230	300

TITANIUM**STERILE****Cortical screw \varnothing 5.2mm**

Code	L. (mm)
DT352022	22.5
DT352025	25
DT352027	27.5
DT352030	30
DT352032	32.5
DT352035	35
DT352037	37.5
DT352040	40

Code	L. (mm)
DT352042	42.5
DT352045	45
DT352047	47.5
DT352050	50
DT352052	52.5
DT352055	55
DT352060	60
DT352065	65

Code	L. (mm)
DT352070	70
DT352075	75
DT352080	80
DT352085	85
DT352090	90
DT352095	95
DT352100	100
DT352105	105
DT352110	110

End cap

Code	L.
DT360000	0 mm
DT360005	5 mm

Talo-calcaneal compression cap

Code	L.
DT360030	STD

on request

ESTREMO Generic instrument set

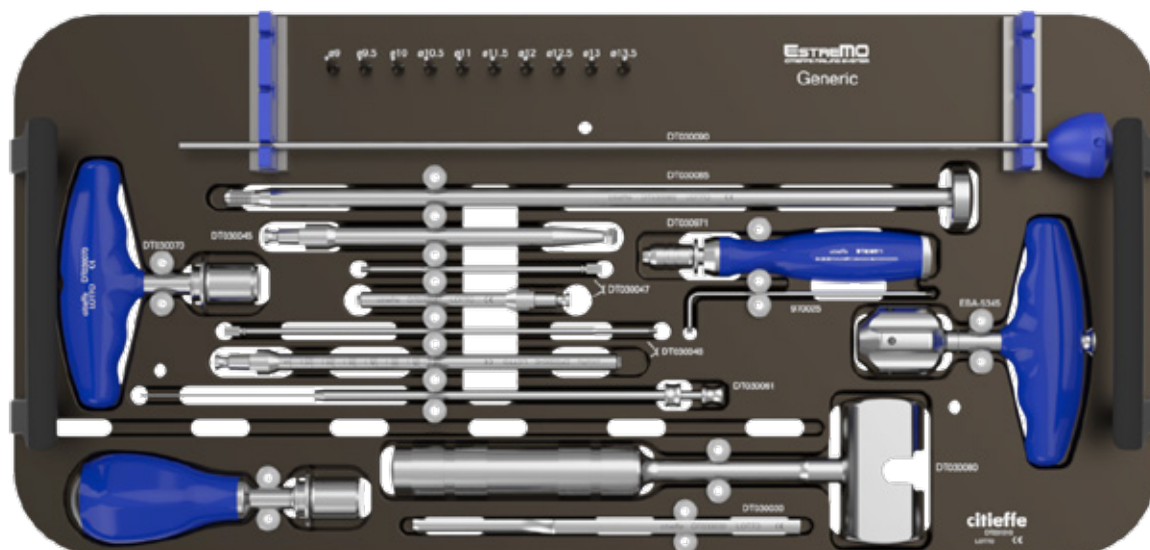

Code	Description	Qty
EBA-5345	Chuck for ø2.5-3mm wire	1
970025	Allen wrench 2.5mm	1
DT030030	Screws ruler	1
DT030045	Wrench, 8mm Hudson coupling, short	1
DT030046	Screwdriver, 5mm Hudson coupling	1
DT030047	Screwdriver, 5mm Hudson coupling, short	1
DT030061	Screws depth gauge	1
DT030070	Cannulated T-handle with Hudson coupling	1
DT030080	Slotted hammer	1
DT030085	Extractor, threaded M8x1	1
DT030090	Obturator with handle	1
DT030971	Cannulated "D20" handle with AO coupling	1
DT031010	ESTREMO instrument set tray, generic empty	1
34.680-RAL5010	Cannulated Teardrop-handle with Hudson coupling	1

***NOTE:**

The tray has holders to accommodate reamers heads with sizes from ø9mm to ø13.5mm (ø2.7mm inner hole) and two flexible reamer stems.

ESTREMO Ankle fusion instrument set

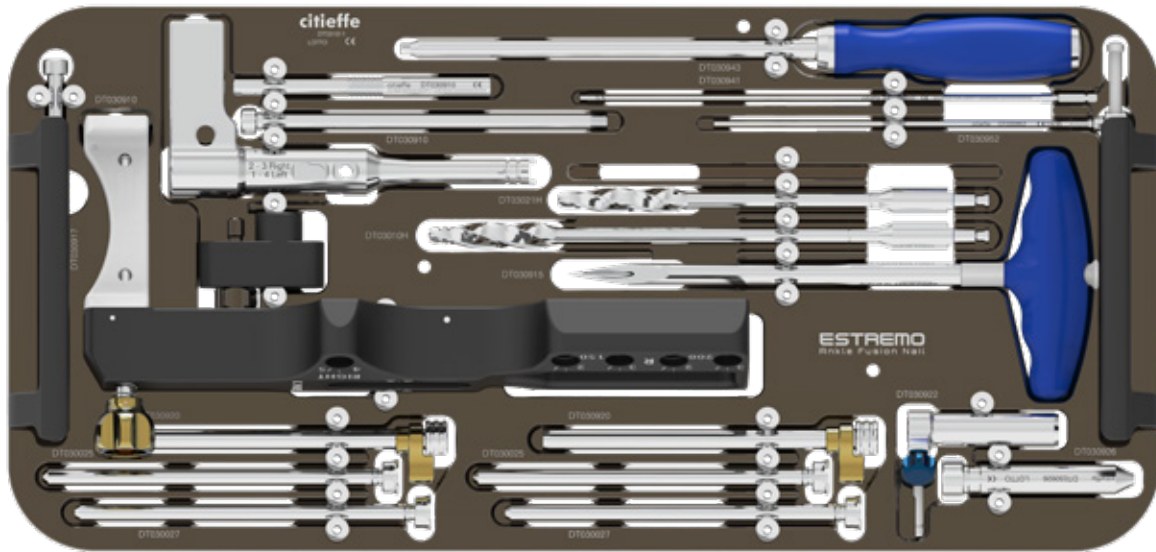

Code	Description	Qty
DT030025	Trocar \varnothing 3mm	2
DT030027	Trocar for drill bit, \varnothing 4mm	2
DT03010H	Cannulated reamer, \varnothing 12.5mm	1
DT03021H	Cannulated reamer \varnothing 11.5mm	1
DT030910	ESTREMO ankle fusion guide	1
DT030917	Nail connection bolt, ESTREMO Ankle guide (Spare part)	1
DT030915	Manual cannulated awl \varnothing 10mm	1
DT030920	Cannula	2
DT030922	Soft tissue protection sleeve AO joint	1
DT030926	Multi-hole trocar	1
DT030941	Hexagonal screwdriver for compression, 3.5mm	1
DT030943	Hexagonal screwdriver, 5mm	1
DT030952	Talo-calcaneal compression device	1
DT031011	ESTREMO instrument set tray, ankle fusion empty	1

Sterile disposables

STERILE

Code	Description	Q.ty
66987	Guide wire, trocar tip \varnothing 3x350mm	4
EBA-5304	Guide wire with olive \varnothing 2.5x800mm	4
DT03013A	Graduated drill bit, \varnothing 4x350mm	2
DT03015A	Drill bit, \varnothing 4x350mm	optional
DT03016A	Drill bit, \varnothing 4x195mm	2
DT03019A	Drill bit, \varnothing 4x110mm	2
DT030965	Radiolucent trocar \varnothing 3mm	optional
DT030962	Nails ruler kit with Guide wire with olive \varnothing 2.5x800mm	optional
DT030942	Hexagonal screwdriver for compression, 3.5mm	optional
DT030968	Countersink for ESTREMO screws \varnothing 5.2mm Hudson	optional

Optional instruments **NOT STERILE**

Code	Description
DT030031	Template nails length

ESTREMO

Ankle Fusion Nail

Intramedullary Ankle Fusion Nail



Citieffe s.r.l.

Via Armadori, 21, 40012 Calderara di Reno (BO) - Italy
Tel +39 051 721850 - Fax +39 051 721870
info@citieffe.com | www.citieffe.com

Citieffe Inc.

3692 Grand Ave #473 Miami, Florida 33133 USA
info-usa@citieffe.com | orders-usa@citieffe.com
www.citieffe.com/us/



For more information scan
the Qrcode

DISTRIBUTOR